

KANTBP 3.0: New version of a program for computing energy levels, reflection and transmission matrices, and corresponding wave functions in the coupled-channel adiabatic approach

A.A. Gusev^{1,*}, O. Chuluunbaatar^{1,2,†}, S.I. Vinitzky¹, and A.G. Abrashkevich³

¹ *Joint Institute for Nuclear Research, Dubna, 141980 Moscow region, Russia*

² *National University of Mongolia, Ulaanbaatar, Mongolia and*

³ *IBM Toronto Lab, 8200 Warden Avenue, Markham, ON L6G 1C7, Canada*

A FORTRAN 77 program for calculating energy values, reflection and transmission matrices, and corresponding wave functions in a coupled-channel approximation of the adiabatic approach is presented. In this approach, a multidimensional Schrödinger equation is reduced to a system of the coupled second-order ordinary differential equations on a finite interval with the homogeneous boundary conditions of the third type at the left- and right-boundary points for continuous spectrum problem, or a set of first, second and third type boundary conditions for discrete spectrum problem. The resulting system of these equations containing the potential matrix elements and first-derivative coupling terms is solved using high-order accuracy approximations of the finite element method. Efficiency of the schemes proposed is demonstrated on an example of solution of quantum transmittance problem for a pair of coupled ions through the repulsive Coulomb barriers. As a test desk, the program is applied to the calculation of the reflection and transmission matrices and corresponding wave functions for the two-dimensional problem with different barrier potentials.

I. INTRODUCTION

In our previous paper [1] we have described the finite element method procedure based on the use of high-order accuracy approximations for calculating approximate eigensolutions of the discrete and continuous spectrum for systems of coupled differential equations on a finite interval of the variable $z \in [z_{\min}, z_{\max}]$ with the homogeneous boundary conditions: the Dirichlet, Neumann at $z = z_{\min}$; the Dirichlet, Neumann and the third-type at $z = z_{\max}$.

In the next paper [2] we applied a general homogeneous boundary conditions of the third-type at $z = z_{\min} > 0$ for calculating approximate eigensolutions of the continuous spectrum problem. The third-type boundary conditions at $z = z_{\min} > 0$ are formulated by using known asymptotics for a set of linear independent regular solutions for problems under consideration.

The purpose of this work is to extend the framework of papers [1, 2] for calculating approximate eigensolutions of the continuous spectrum for systems of coupled differential equations on finite intervals of the variable $z \in [z_{\min}, z_{\max}]$ using a general homogeneous boundary condition of the third-type at $z = z_{\min} < 0$ and $z = z_{\max} > 0$. The third-type boundary conditions are formulated for problems under consideration by using known asymptotics for a set of linear independent asymptotic regular and irregular solutions in the open channels, and a set of linear independent regular asymptotic solutions in the closed channels, respectively. This approach can be used in calculations of effects of electron screening on low-energy fusion cross sections [3–6], channeling processes [7, 8], threshold phenomena in the formation and ionization of (anti)hydrogen-like atoms and ions in magnetic traps [9, 10], scattering problem for quantum dots and quantum wires in magnetic field [11–14], potential scattering with confinement potentials [15], penetration through a two-dimensional fission barrier [16, 17], tunneling from false vacuum of two interacted particles [18, 19] and three-dimensional tunneling of a diatomic molecule incident upon a potential barrier [20].

In this work we analyze an effect of quantum transparency consisting of nonmonotonical dependence of transmission coefficient at resonance tunneling of a pair of particles connected by oscillator interaction potential throughout Coulomb-like barriers [21].

The paper is organized as follows. In Section II we give a brief overview of the problem. A description of the new version of the KANTBP program is given in Section III. Benchmark calculations are given in Section V. Test desk is discussed in Section VI.

*Electronic address: gooseff@jinr.ru

†Electronic address: chuka@jinr.ru

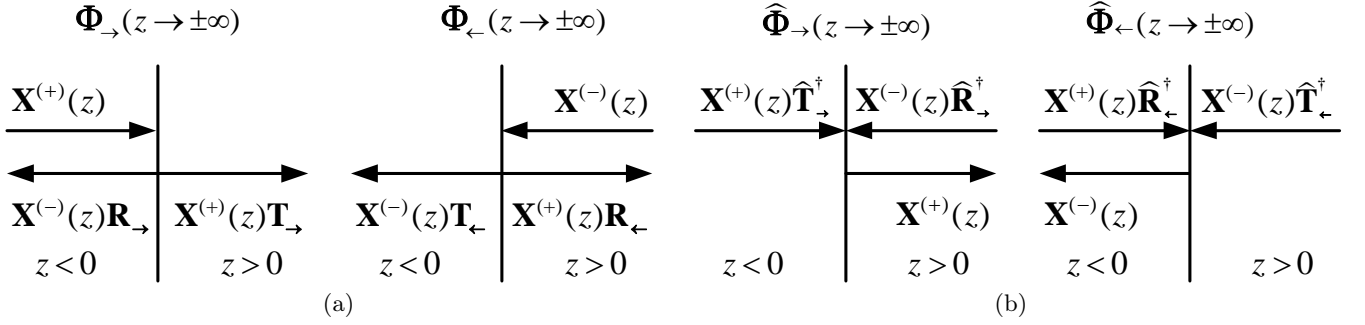

FIG. 1: Schematic diagrams of the continuous spectrum waves having the asymptotic form: (a) “incident wave + outgoing waves”, (b) “incident waves + ingoing wave”.

II. STATEMENT OF THE PROBLEM

In the Kantorovich approach [1, 22], the multidimensional Schrödinger equation is reduced to a finite set of N ordinary second-order differential equations on the finite interval $[z_{\min}, z_{\max}]$ for the partial solution $\chi^{(j)}(z) = (\chi_1^{(j)}(z), \dots, \chi_N^{(j)}(z))^T$

$$(\mathbf{L} - 2E\mathbf{I})\chi^{(j)}(z) \equiv \left(-\mathbf{I}\frac{1}{z^{d-1}}\frac{d}{dz}z^{d-1}\frac{d}{dz} + \mathbf{V}(z) + \mathbf{Q}(z)\frac{d}{dz} + \frac{1}{z^{d-1}}\frac{dz^{d-1}\mathbf{Q}(z)}{dz} - 2E\mathbf{I} \right)\chi^{(j)}(z) = 0. \quad (1)$$

Here \mathbf{I} , $\mathbf{V}(z)$ and $\mathbf{Q}(z)$ are the unit, symmetric and antisymmetric $N \times N$ matrices, respectively. We assume that $d = 1$, and $\mathbf{V}(z)$ and $\mathbf{Q}(z)$ matrices have the following asymptotic behaviour at large $z = z_{\pm} \rightarrow \pm\infty$

$$V_{ij}(z_{\pm}) = \left(\epsilon_j + \frac{2Z_j^{\pm}}{z_{\pm}} \right) \delta_{ij} + \sum_{l=2} \frac{v_{ij}^{(l,\pm)}}{z_{\pm}^l}, \quad Q_{ij}(z_{\pm}) = \sum_{l=1} \frac{q_{ij}^{(l,\pm)}}{z_{\pm}^l}, \quad (2)$$

where $\epsilon_1 \leq \dots \leq \epsilon_N$ are the threshold values, and δ_{ij} is the Kronecker symbol.

In the present work, scattering problem is solved using the homogeneous third-type boundary conditions at $z = z_{\min} \ll 0$ and $z = z_{\max} \gg 0$:

$$\left. \frac{d\Phi(z)}{dz} \right|_{z=z_{\min}} = \mathcal{R}(z_{\min})\Phi(z_{\min}), \quad \left. \frac{d\Phi(z)}{dz} \right|_{z=z_{\max}} = \mathcal{R}(z_{\max})\Phi(z_{\max}), \quad (3)$$

where $\mathcal{R}(z)$ is a unknown $N \times N$ matrix-function, $\Phi(z) = \{\chi^{(j)}(z)\}_{j=1}^{N_o}$ is the required $N \times N_o$ matrix-solution and N_o is the number of open channels, $N_o = \max_{2E \geq \epsilon_j} j \leq N$. From this we obtain the quadratic functional at $d = 1$ (similar to Eq. (23) in [1] and Eq. (5) in [2])

$$\Xi(\Phi, E, z_{\min}, z_{\max}) \equiv \int_{z_{\min}}^{z_{\max}} \Phi^{\dagger}(z) (\mathbf{L} - 2E\mathbf{I}) \Phi(z) dz = \Pi(\Phi, E, z_{\min}, z_{\max}) - \Phi^{\dagger}(z_{\max})\mathbf{G}(z_{\max})\Phi(z_{\max}) + \Phi^{\dagger}(z_{\min})\mathbf{G}(z_{\min})\Phi(z_{\min}), \quad (4)$$

where $\Pi(\Phi, E, z_{\min}, z_{\max})$ is the symmetric functional

$$\Pi(\Phi, E, z_{\min}, z_{\max}) = \int_{z_{\min}}^{z_{\max}} \left[\frac{d\Phi^{\dagger}(z)}{dz} \frac{d\Phi(z)}{dz} + \Phi^{\dagger}(z)\mathbf{V}(z)\Phi(z) + \Phi^{\dagger}(z)\mathbf{Q}(z)\frac{d\Phi(z)}{dz} - \frac{d\Phi(z)^{\dagger}}{dz}\mathbf{Q}(z)\Phi(z) - 2E\Phi^{\dagger}(z)\Phi(z) \right] dz, \quad (5)$$

and $\mathbf{G}(z) = \mathcal{R}(z) - \mathbf{Q}(z)$ is the $N \times N$ matrix-function which should be symmetric according to the conventional \mathbf{R} -matrix theory [23]. Here the symbol \dagger denotes the transjugate of a matrix.

A. The physical scattering asymptotic forms of solutions in longitudinal coordinates and scattering matrix

Matrix-solution $\Phi_v(z) = \Phi(z)$ describing the incidence of the particle and its scattering, which has the asymptotic form “incident wave + outgoing waves” (see Figure 1a), is

$$\Phi_v(z \rightarrow \pm\infty) = \begin{cases} \begin{cases} \mathbf{X}^{(+)}(z)\mathbf{T}_v, & z > 0, \\ \mathbf{X}^{(+)}(z) + \mathbf{X}^{(-)}(z)\mathbf{R}_v, & z < 0, \end{cases} & v = \rightarrow, \\ \begin{cases} \mathbf{X}^{(-)}(z) + \mathbf{X}^{(+)}(z)\mathbf{R}_v, & z > 0, \\ \mathbf{X}^{(-)}(z)\mathbf{T}_v, & z < 0, \end{cases} & v = \leftarrow, \end{cases} \quad (6)$$

where \mathbf{R}_v and \mathbf{T}_v are the reflection and transmission $N_o \times N_o$ matrices, $v = \rightarrow$ and $v = \leftarrow$ denote the initial direction of the particle motion along the z axis. Here the leading term of the asymptotic rectangle-matrix functions $\mathbf{X}^{(\pm)}(z)$ has the form [9, 10]

$$X_{ij}^{(\pm)}(z) \rightarrow p_j^{-1/2} \exp\left(\pm i\left(p_j z - \frac{Z_j}{p_j} \ln(2p_j|z|)\right)\right) \delta_{ij}, \quad (7)$$

$$p_j = \sqrt{2E - \epsilon_j} \quad i = 1, \dots, N, \quad j = 1, \dots, N_o,$$

where $Z_j = Z_j^+$ at $z > 0$ and $Z_j = Z_j^-$ at $z < 0$. The matrix-solution $\Phi_v(z, E)$ is normalized by

$$\int_{-\infty}^{\infty} \Phi_{v'}^\dagger(z, E') \Phi_v(z, E) dz = 2\pi \delta(E' - E) \delta_{v'v} \mathbf{I}_{oo}, \quad (8)$$

where \mathbf{I}_{oo} is the unit $N_o \times N_o$ matrix.

Let us rewrite Eq. (6) in the matrix form at $z_+ \rightarrow +\infty$ and $z_- \rightarrow -\infty$ as

$$\begin{pmatrix} \Phi_{\rightarrow}(z_+) & \Phi_{\leftarrow}(z_+) \\ \Phi_{\rightarrow}(z_-) & \Phi_{\leftarrow}(z_-) \end{pmatrix} = \begin{pmatrix} \mathbf{0} & \mathbf{X}^{(-)}(z_+) \\ \mathbf{X}^{(+)}(z_-) & \mathbf{0} \end{pmatrix} + \begin{pmatrix} \mathbf{0} & \mathbf{X}^{(+)}(z_+) \\ \mathbf{X}^{(-)}(z_-) & \mathbf{0} \end{pmatrix} \mathbf{S}, \quad (9)$$

where the scattering matrix \mathbf{S}

$$\mathbf{S} = \begin{pmatrix} \mathbf{R}_{\rightarrow} & \mathbf{T}_{\leftarrow} \\ \mathbf{T}_{\rightarrow} & \mathbf{R}_{\leftarrow} \end{pmatrix} \quad (10)$$

is composed of the reflection and transmission matrices. In addition, it should be noted that functions $\mathbf{X}^{(\pm)}(z)$ satisfy relations

$$\mathbf{Wr}(\mathbf{Q}(z); \mathbf{X}^{(\mp)}(z), \mathbf{X}^{(\pm)}(z)) = \pm 2i \mathbf{I}_{oo}, \quad \mathbf{Wr}(\mathbf{Q}(z); \mathbf{X}^{(\pm)}(z), \mathbf{X}^{(\pm)}(z)) = \mathbf{0}, \quad (11)$$

where $\mathbf{Wr}(\bullet; \mathbf{a}(z), \mathbf{b}(z))$ is a generalized Wronskian with a long derivative defined as

$$\mathbf{Wr}(\bullet; \mathbf{a}(z), \mathbf{b}(z)) = \mathbf{a}^T(z) \left(\frac{d\mathbf{b}(z)}{dz} - \bullet \mathbf{b}(z) \right) - \left(\frac{d\mathbf{a}(z)}{dz} - \bullet \mathbf{a}(z) \right)^T \mathbf{b}(z). \quad (12)$$

This Wronskian will be used to estimate a desirable accuracy of the asymptotic expansions (7) and (17). Here the symbol T denotes the transpose of a matrix.

Let us show that the scattering matrix (10) is symmetric and unitary. Using Eqs. (6) and (11), we have following relations

$$\begin{aligned} \mathbf{Wr}(\mathbf{Q}(z); \Phi_{\rightarrow}^*(z), \Phi_{\rightarrow}(z)) &= \begin{cases} +2i \mathbf{T}_{\rightarrow}^\dagger \mathbf{T}_{\rightarrow}, & z > 0, \\ +2i (\mathbf{I}_{oo} - \mathbf{R}_{\rightarrow}^\dagger \mathbf{R}_{\rightarrow}), & z < 0, \end{cases} \\ \mathbf{Wr}(\mathbf{Q}(z); \Phi_{\leftarrow}^*(z), \Phi_{\leftarrow}(z)) &= \begin{cases} -2i \mathbf{T}_{\leftarrow}^\dagger \mathbf{T}_{\leftarrow}, & z < 0, \\ -2i (\mathbf{I}_{oo} - \mathbf{R}_{\leftarrow}^\dagger \mathbf{R}_{\leftarrow}), & z > 0, \end{cases} \\ \mathbf{Wr}(\mathbf{Q}(z); \Phi_{\rightarrow}^*(z), \Phi_{\leftarrow}(z)) &= \begin{cases} +2i \mathbf{T}_{\rightarrow}^\dagger \mathbf{R}_{\leftarrow}, & z > 0, \\ -2i \mathbf{R}_{\rightarrow}^\dagger \mathbf{T}_{\leftarrow}, & z < 0, \end{cases} \\ \mathbf{Wr}(\mathbf{Q}(z); \Phi_{\leftarrow}^*(z), \Phi_{\rightarrow}(z)) &= \begin{cases} +2i \mathbf{R}_{\leftarrow}^\dagger \mathbf{T}_{\rightarrow}, & z > 0, \\ -2i \mathbf{T}_{\leftarrow}^\dagger \mathbf{R}_{\rightarrow}, & z < 0, \end{cases} \end{aligned} \quad (13)$$

$$\begin{aligned}\text{Wr}(\mathbf{Q}(z); \Phi_{\rightarrow}(z), \Phi_{\leftarrow}(z)) &= \begin{cases} -2\mathbf{T}_{\rightarrow}^T, & z > 0, \\ -2\mathbf{T}_{\leftarrow}, & z < 0, \end{cases} \\ \text{Wr}(\mathbf{Q}(z); \Phi_{\rightarrow}(z), \Phi_{\rightarrow}(z)) &= \begin{cases} +\mathbf{0}, & z > 0, \\ +2\mathbf{l}(\mathbf{R}_{\rightarrow}^T - \mathbf{R}_{\rightarrow}), & z < 0, \end{cases} \\ \text{Wr}(\mathbf{Q}(z); \Phi_{\leftarrow}(z), \Phi_{\leftarrow}(z)) &= \begin{cases} -2\mathbf{l}(\mathbf{R}_{\leftarrow}^T - \mathbf{R}_{\leftarrow}), & z > 0, \\ +\mathbf{0}, & z < 0, \end{cases}\end{aligned}$$

where the asterisk denotes the conjugate of a matrix. From here, we obtain the following properties of the reflection and transmission matrices:

$$\begin{aligned}\mathbf{T}_{\rightarrow}^{\dagger} \mathbf{T}_{\rightarrow} + \mathbf{R}_{\rightarrow}^{\dagger} \mathbf{R}_{\rightarrow} &= \mathbf{I}_{oo} = \mathbf{T}_{\leftarrow}^{\dagger} \mathbf{T}_{\leftarrow} + \mathbf{R}_{\leftarrow}^{\dagger} \mathbf{R}_{\leftarrow}, \\ \mathbf{T}_{\rightarrow}^{\dagger} \mathbf{R}_{\leftarrow} + \mathbf{R}_{\rightarrow}^{\dagger} \mathbf{T}_{\leftarrow} &= \mathbf{0} = \mathbf{R}_{\leftarrow}^{\dagger} \mathbf{T}_{\rightarrow} + \mathbf{T}_{\leftarrow}^{\dagger} \mathbf{R}_{\rightarrow}, \\ \mathbf{T}_{\rightarrow}^T &= \mathbf{T}_{\leftarrow}, \quad \mathbf{R}_{\rightarrow}^T = \mathbf{R}_{\rightarrow}, \quad \mathbf{R}_{\leftarrow}^T = \mathbf{R}_{\leftarrow}.\end{aligned}\tag{14}$$

This means that the scattering matrix (10) is symmetric and unitary.

Also matrix-solution $\hat{\Phi}_v(z) = \Phi(z)$ describing the incidence of the particle and its scattering, which has the inverse asymptotic form ‘‘incident waves + ingoing wave’’ (see Figure 1b), is

$$\hat{\Phi}_v(z \rightarrow \pm\infty) = \begin{cases} \begin{cases} \mathbf{X}^{(+)}(z) + \mathbf{X}^{(-)}(z) \hat{\mathbf{R}}_v^{\dagger}, & z > 0, \\ \mathbf{X}^{(+)}(z) \hat{\mathbf{T}}_v^{\dagger}, & z < 0, \end{cases} & v = \rightarrow, \\ \begin{cases} \mathbf{X}^{(-)}(z) \hat{\mathbf{T}}_v^{\dagger}, & z > 0, \\ \mathbf{X}^{(-)}(z) + \mathbf{X}^{(+)}(z) \hat{\mathbf{R}}_v^{\dagger}, & z < 0, \end{cases} & v = \leftarrow.\end{cases}\tag{15}$$

Note, that an equality $\hat{\Phi}_{\rightarrow}^*(z) = \Phi_{\leftarrow}(z)$ should be fulfilled from which we obtain $\hat{\mathbf{R}}_{\rightarrow} = \mathbf{R}_{\leftarrow}$, $\hat{\mathbf{R}}_{\leftarrow} = \mathbf{R}_{\rightarrow}$, $\hat{\mathbf{T}}_v = \mathbf{T}_v$. Therefore we consider below only matrix-solution $\Phi_v(z)$.

B. Calculation of matrices $\mathbf{G}(z_{\min})$ at $v = \leftarrow$ and $\mathbf{G}(z_{\max})$ at $v = \rightarrow$

Suppose that a set of linear independent regular square-solutions $\Phi_v^{\text{reg}}(z) = \{\chi_{\text{reg}}^{(j)}(z)\}_{j=1}^N$ for a problem under consideration is known at $z < 0$, $v = \leftarrow$ and at $z > 0$, $v = \rightarrow$, i.e.,

$$\begin{aligned}\Phi_{\leftarrow}^{\text{reg}}(z) &= \tilde{\mathbf{X}}^{(-)}(z), \quad z < 0, \quad v = \leftarrow, \quad \text{and} \quad \Phi_{\rightarrow}^{\text{reg}}(z) = \tilde{\mathbf{X}}^{(+)}(z), \quad z > 0, \quad v = \rightarrow, \\ \tilde{X}_{ij}^{(\mp)}(z) &= X_{ij}^{(\mp)}(z), \quad i = 1, \dots, N, \quad j = 1, \dots, N_o.\end{aligned}\tag{16}$$

In the case of some channels are closed, we use additional linear independent regular asymptotic functions:

$$\begin{aligned}\tilde{X}_{ij}^{(-)}(z) &\rightarrow q_j^{-1/2} \exp\left(+\left(q_j z + \frac{Z_j}{q_j} \ln(2q_j |z|)\right)\right) \delta_{ij}, \quad z < 0, \quad v = \leftarrow, \\ \tilde{X}_{ij}^{(+)}(z) &\rightarrow q_j^{-1/2} \exp\left(-\left(q_j z + \frac{Z_j}{q_j} \ln(2q_j |z|)\right)\right) \delta_{ij}, \quad z > 0, \quad v = \rightarrow, \\ q_j &= \sqrt{\epsilon_j - 2E}, \quad i = 1, \dots, N, \quad j = N_o + 1, \dots, N.\end{aligned}\tag{17}$$

Then as shown in [2], the $\mathbf{G}(z)$ matrix at $z = z_{\min} < 0$, $v = \leftarrow$ and at $z = z_{\max} > 0$, $v = \rightarrow$ can be found via the known set of linear independent regular solutions $\Phi_v^{\text{reg}}(z)$:

$$\mathbf{G}(z) = \mathcal{R}(z) - \mathbf{Q}(z) = \frac{d\Phi_v^{\text{reg}}(z)}{dz} (\Phi_v^{\text{reg}}(z))^{-1} - \mathbf{Q}(z) \equiv (\mathcal{R}(z) + \mathcal{R}^T(z))/2.\tag{18}$$

C. Calculation of matrix-solution $\Phi_v(z)$

After using the high-order accuracy approximations of the finite element method [1, 2, 24], the solution of a multichannel scattering problem at a fixed value of energy E in open channels is reduced to a solution of the following algebraic problem with respect to matrix-solution $\Phi^h \equiv ((\chi^{(1)})^h, \dots, (\chi^{(N_o)})^h)$

$$\mathbf{G}^p \Phi^h \equiv (\mathbf{A}^p - 2E \mathbf{B}^p) \Phi^h = (\mathbf{M}_{\max}^p - \mathbf{M}_{\min}^p) \Phi^h,\tag{19}$$

$$\frac{d\Phi^h(z)}{dz} = (\mathbf{G}(z) + \mathbf{Q}(z)) \Phi^h(z), \quad z = z_{\min}, \quad z = z_{\max},\tag{20}$$

where \mathbf{A}^p and \mathbf{B}^p are the symmetric $(LN) \times (LN)$ matrices, L is the number of the nodes of the finite element grid on interval $[z_{\min}, z_{\max}]$, \mathbf{M}_{\max}^p and \mathbf{M}_{\min}^p are matrices with zero elements except the right-lower and left-upper $N \times N$ matrices equal to $\mathbf{G}(z_{\max})$ and $\mathbf{G}(z_{\min})$, respectively.

First, we consider the numerical algorithm for the calculation of matrix-solution $\Phi^h = \Phi_{\leftarrow}^h$. In this case Eq. (19) can be rewritten in the following form

$$(\mathbf{G}^p + \mathbf{M}_{\min}^p) \begin{pmatrix} \Phi_{\leftarrow}^a \\ \Phi_{\leftarrow}^b \end{pmatrix} \equiv \begin{pmatrix} \mathbf{G}_{\leftarrow}^{aa} & \mathbf{G}_{\leftarrow}^{ab} \\ \mathbf{G}_{\leftarrow}^{ba} & \mathbf{G}_{\leftarrow}^{bb} \end{pmatrix} \begin{pmatrix} \Phi_{\leftarrow}^a \\ \Phi_{\leftarrow}^b \end{pmatrix} = \begin{pmatrix} \mathbf{0} & \mathbf{0} \\ \mathbf{0} & \mathbf{G}(z_{\max}) \end{pmatrix} \begin{pmatrix} \Phi_{\leftarrow}^a \\ \Phi_{\leftarrow}^b \end{pmatrix}, \quad (21)$$

where Φ_{\leftarrow}^a and $\Phi_{\leftarrow}^b \equiv \Phi_{\leftarrow}(z_{\max})$ are the matrix-solutions of dimension $(LN - N) \times N_o$ and $N \times N_o$, respectively. From here, we obtain explicit expressions

$$\Phi_{\leftarrow}^a = -(\mathbf{G}_{\leftarrow}^{aa})^{-1} \mathbf{G}_{\leftarrow}^{ab} \Phi_{\leftarrow}^b, \quad \mathbf{G}(z_{\max}) = \mathbf{G}_{\leftarrow}^{bb} - \mathbf{G}_{\leftarrow}^{ba} (\mathbf{G}_{\leftarrow}^{aa})^{-1} \mathbf{G}_{\leftarrow}^{ab}. \quad (22)$$

From Eqs. (20) and (22) we can obtain the relation between Φ_{\leftarrow}^b and its derivative

$$\frac{d\Phi_{\leftarrow}^b}{dz} = \mathcal{R}(z_{\max}) \Phi_{\leftarrow}^b, \quad \mathcal{R}(z_{\max}) = \mathbf{G}(z_{\max}) + \mathbf{Q}(z_{\max}). \quad (23)$$

Note, that matrix $\mathbf{G}(z_{\max})$ is determined via the inverse of submatrix $\mathbf{G}_{\leftarrow}^{aa}$ calculation of which requires substantial computer resources. For evaluating Eq. (23) without such calculation of the inverse of submatrix $\mathbf{G}_{\leftarrow}^{aa}$, let's consider the following auxiliary system of algebraic equations

$$\begin{pmatrix} \mathbf{G}_{\leftarrow}^{aa} & \mathbf{G}_{\leftarrow}^{ab} \\ \mathbf{G}_{\leftarrow}^{ba} & \mathbf{G}_{\leftarrow}^{bb} \end{pmatrix} \begin{pmatrix} \mathbf{F}_{\leftarrow}^a \\ \mathbf{F}_{\leftarrow}^b \end{pmatrix} = \begin{pmatrix} \mathbf{0} \\ \mathbf{I} \end{pmatrix}. \quad (24)$$

As the determinant of the matrix $\mathbf{G}^p + \mathbf{M}_{\min}^p$ is nonzero, the above equation has a unique solution

$$\mathbf{F}_{\leftarrow}^a = -(\mathbf{G}_{\leftarrow}^{aa})^{-1} \mathbf{G}_{\leftarrow}^{ab} \mathbf{F}_{\leftarrow}^b, \quad \mathbf{F}_{\leftarrow}^b = (\mathbf{G}_{\leftarrow}^{bb} - \mathbf{G}_{\leftarrow}^{ba} (\mathbf{G}_{\leftarrow}^{aa})^{-1} \mathbf{G}_{\leftarrow}^{ab})^{-1}. \quad (25)$$

Taking this into account, the required $\mathcal{R}(z_{\max})$ matrix is equal to

$$\mathcal{R}(z_{\max}) = (\mathbf{F}_{\leftarrow}^b)^{-1} + \mathbf{Q}(z_{\max}). \quad (26)$$

Using Eqs. (23) and (6), we obtain the following matrix equation for the reflection \mathbf{R}_{\leftarrow} matrix:

$$\mathbf{Y}_{\leftarrow}^{(+)}(z_{\max}) \mathbf{R}_{\leftarrow} = -\mathbf{Y}_{\leftarrow}^{(-)}(z_{\max}), \quad \mathbf{Y}_{\leftarrow}^{(\pm)}(z) = \frac{d\mathbf{X}^{(\pm)}(z)}{dz} - \mathcal{R}(z) \mathbf{X}^{(\pm)}(z). \quad (27)$$

Then the required solution Φ_{\leftarrow}^h is calculated by formulae (6), (22) and (25)

$$\Phi_{\leftarrow}^b = \mathbf{X}^{(-)}(z_{\max}) + \mathbf{X}^{(+)}(z_{\max}) \mathbf{R}_{\leftarrow}, \quad \Phi_{\leftarrow}^a = \mathbf{F}_{\leftarrow}^a (\mathbf{F}_{\leftarrow}^b)^{-1} \Phi_{\leftarrow}^b. \quad (28)$$

The transmission \mathbf{T}_{\leftarrow} matrix is determined from the matrix equation

$$\mathbf{X}^{(-)}(z_{\min}) \mathbf{T}_{\leftarrow} = \Phi_{\leftarrow}^h(z_{\min}).$$

Note that, when some channels are closed, the $\mathbf{Y}_{\leftarrow}^{(\pm)}(z)$ and $\mathbf{X}^{(-)}(z)$ are rectangular $N \times N_o$ matrices. Therefore, using the pseudoinverse matrices of $\mathbf{Y}_{\leftarrow}^{(+)}(z)$ and $\mathbf{X}^{(-)}(z)$, we obtain the following formulae:

$$\begin{aligned} \mathbf{R}_{\leftarrow} &= - \left(\left(\mathbf{Y}_{\leftarrow}^{(+)}(z_{\max}) \right)^T \mathbf{Y}_{\leftarrow}^{(+)}(z_{\max}) \right)^{-1} \left(\mathbf{Y}_{\leftarrow}^{(+)}(z_{\max}) \right)^T \mathbf{Y}_{\leftarrow}^{(-)}(z_{\max}), \\ \mathbf{T}_{\leftarrow} &= \left(\left(\mathbf{X}^{(-)}(z_{\min}) \right)^T \mathbf{X}^{(-)}(z_{\min}) \right)^{-1} \left(\mathbf{X}^{(-)}(z_{\min}) \right)^T \Phi_{\leftarrow}^h(z_{\min}). \end{aligned} \quad (29)$$

Now we will describe briefly a calculational scheme for matrix-solution $\Phi^h = \Phi_{\rightarrow}^h$. The required $\mathcal{R}(z_{\min})$ matrix is equal to

$$\mathcal{R}(z_{\min}) = (\mathbf{F}_{\rightarrow}^a)^{-1} + \mathbf{Q}(z_{\min}), \quad (30)$$

and required solution Φ_{\rightarrow}^h is calculated as

$$\Phi_{\rightarrow}^b = \mathbf{F}_{\rightarrow}^b (\mathbf{F}_{\rightarrow}^a)^{-1} \Phi_{\rightarrow}^a, \quad \Phi_{\rightarrow}^a = \mathbf{X}^{(+)}(z_{\min}) + \mathbf{X}^{(-)}(z_{\min}) \mathbf{R}_{\rightarrow}. \quad (31)$$

Here $\Phi_{\rightarrow}^a \equiv \Phi_{\rightarrow}(z_{\min})$ and Φ_{\rightarrow}^b are the matrix-solutions of dimension $N \times N_o$ and $(LN - N) \times N_o$. $\mathbf{F}_{\rightarrow}^a$ and $\mathbf{F}_{\rightarrow}^b$ are the matrices of dimension $N \times N$ and $(LN - N) \times N$ which are the solutions of the auxiliary system of algebraic equations

$$(\mathbf{G}^p - \mathbf{M}_{\max}^p) \begin{pmatrix} \mathbf{F}_{\rightarrow}^a \\ \mathbf{F}_{\rightarrow}^b \end{pmatrix} \equiv \begin{pmatrix} \mathbf{G}_{\rightarrow}^{aa} & \mathbf{G}_{\rightarrow}^{ab} \\ \mathbf{G}_{\rightarrow}^{ba} & \mathbf{G}_{\rightarrow}^{bb} \end{pmatrix} \begin{pmatrix} \mathbf{F}_{\rightarrow}^a \\ \mathbf{F}_{\rightarrow}^b \end{pmatrix} = - \begin{pmatrix} \mathbf{I} \\ \mathbf{0} \end{pmatrix}. \quad (32)$$

Finally, we obtain the following matrix equations for the reflection \mathbf{R}_{\rightarrow} and transmission \mathbf{T}_{\rightarrow} matrices:

$$\begin{aligned} \mathbf{Y}_{\rightarrow}^{(-)}(z_{\min}) \mathbf{R}_{\rightarrow} &= -\mathbf{Y}_{\rightarrow}^{(+)}(z_{\min}), \quad \mathbf{Y}_{\rightarrow}^{(\pm)}(z) = \frac{d\mathbf{X}^{(\pm)}(z)}{dz} - \mathcal{R}(z) \mathbf{X}^{(\pm)}(z), \\ \mathbf{X}^{(+)}(z_{\max}) \mathbf{T}_{\rightarrow} &= \Phi_{\rightarrow}^h(z_{\max}). \end{aligned} \quad (33)$$

The reflection \mathbf{R}_{\rightarrow} and transmission \mathbf{T}_{\rightarrow} matrices are evaluated using the pseudoinverse matrices of $\mathbf{Y}_{\rightarrow}^{(-)}(z_{\min})$ and $\mathbf{X}^{(+)}(z_{\max})$:

$$\begin{aligned} \mathbf{R}_{\rightarrow} &= - \left(\left(\mathbf{Y}_{\rightarrow}^{(-)}(z_{\min}) \right)^T \mathbf{Y}_{\rightarrow}^{(-)}(z_{\min}) \right)^{-1} \left(\mathbf{Y}_{\rightarrow}^{(-)}(z_{\min}) \right)^T \mathbf{Y}_{\rightarrow}^{(+)}(z_{\min}), \\ \mathbf{T}_{\rightarrow} &= \left(\left(\mathbf{X}^{(+)}(z_{\max}) \right)^T \mathbf{X}^{(+)}(z_{\max}) \right)^{-1} \left(\mathbf{X}^{(+)}(z_{\max}) \right)^T \Phi_{\rightarrow}^h(z_{\max}). \end{aligned} \quad (34)$$

D. Asymptotic forms of regular and irregular solutions in the longitudinal coordinates

We calculate the asymptotic solution to a set of N coupled ordinary differential equations (ODE) at large values of independent variable $|z| \gg 1$

$$\left(-\frac{1}{z^{d-1}} \frac{d}{dz} z^{d-1} \frac{d}{dz} + V_{ii}(z) - 2E \right) \chi_{ii'}(z) = - \sum_{j=1, j \neq i}^N \left(V_{ij}(z) + Q_{ij}(z) \frac{d}{dz} + \frac{1}{z^{d-1}} \frac{d}{dz} z^{d-1} Q_{ij}(z) \right) \chi_{ji'}(z). \quad (35)$$

Here $d \geq 1$ is the dimension of configuration space of a general scattering problem [2]. For the considered case (??), we put $d = 1$ and calculate asymptotic solution on two intervals $-\infty < z \leq z_{\min}$ and $z_{\max} \leq z < +\infty$. We assume that coefficients of Eqs. (35) can be represented in the general asymptotic form as

$$V_{ij}(z) = \left(\epsilon_j^{(0)} + \frac{\epsilon_j^{(1)}}{z} \right) \delta_{ij} + \sum_{l=2}^{k_{\max}+1} \frac{V_{ij}^{(l)}}{z^l}, \quad Q_{ij}(z) = \sum_{l=1}^{k_{\max}+1} \frac{Q_{ij}^{(l)}}{z^l}. \quad (36)$$

Note that in general case coefficients $\epsilon_j^{(1)}$, $V_{ij}^{(l)}$ and $Q_{ij}^{(l)}$ are different for $z > 0$ and $z < 0$. Below we will consider only case of $z > 0$.

Step 1. We construct the solution of Eqs. (35) in the form:

$$\chi_{ji'}(z) = \phi_{ji'}(z) R_{i'}(z) + \psi_{ji'}(z) \frac{dR_{i'}(z)}{dz}, \quad (37)$$

where $\phi_{ji'}(z)$ and $\psi_{ji'}(z)$ are unknown functions, $R_{i'}(z)$ is a known function. We choose $R_{i'}(z)$ as solutions of the auxiliary problem treated like etalon equation $\left(Z_{i'}^{(k < 1)} = Z_{i'}^{(k > k'_{\max})} = 0 \right)$:

$$\left(-\frac{1}{z^{d-1}} \frac{d}{dz} z^{d-1} \frac{d}{dz} + \sum_{k=1}^{k'_{\max}} \frac{Z_{i'}^{(k)}}{z^k} - p_{i'}^2 \right) R_{i'}(z) = 0. \quad (38)$$

Remark 1. If $Z_{i'}^{(k \geq 3)} = 0$ then solutions to the last equation are presented via the hypergeometric functions, exponential, trigonometric, Bessel, Coulomb functions, etc. For example, if the leading terms of the asymptotic solutions are given by formula

$$R_{i'}(z) = \frac{1}{\sqrt{p_{i'} z^{d-1}}} \exp\left(\pm \nu \left(p_{i'} z - \frac{Z_{i'}}{p_{i'}} \ln(2p_{i'} |z|)\right)\right), \quad (39)$$

the coefficients of potential in the etalon equation (38) have the form:

$$Z_{i'}^{(1)} = 2Z_{i'}, \quad Z_{i'}^{(2)} = -\frac{(d-3)(d-1)}{4} \pm \nu \frac{Z_{i'}}{p_{i'}} - \frac{Z_{i'}^2}{p_{i'}^2}. \quad (40)$$

Step 2. At this step we compute the coefficients $\phi_{ji'}(z)$ and $\psi_{ji'}(z)$ of the expansion (37) in the form of series over inverse powers of z :

$$\phi_{ji'}(z) = \sum_{k'=0}^{k_{\max}} \frac{\phi_{ji'}^{(k')}}{z^{k'}}, \quad \psi_{ji'}(z) = \sum_{k'=0}^{k_{\max}} \frac{\psi_{ji'}^{(k')}}{z^{k'}}. \quad (41)$$

After substitution of Eq. (37), (41) into (35) with the use of Eq. (38) and equating the coefficients at $z^{-k'} R_{i'}(z)$ and $z^{-k'} \frac{dR_{i'}(z)}{dz}$, we arrive to a set of recurrent relations at $k' \leq k_{\max}$:

$$\begin{aligned} \left(\epsilon_i^{(0)} - 2E + p_{i'}^2\right) \phi_{ii'}^{(k')} + \left(\epsilon_i^{(1)} - Z_{i'}^{(1)}\right) \phi_{ii'}^{(k'-1)} - 2p_{i'}^2(k'-1) \psi_{ii'}^{(k'-1)} &= -f_{ii'}^{(k')}, \\ \left(\epsilon_i^{(0)} - 2E + p_{i'}^2\right) \psi_{ii'}^{(k')} + 2(k'-1) \phi_{ii'}^{(k'-1)} + \left(\epsilon_i^{(1)} - Z_{i'}^{(1)}\right) \psi_{ii'}^{(k'-1)} &= -g_{ii'}^{(k')}, \end{aligned} \quad (42)$$

where the right hand sides $f_{ii'}^{(k')}$ and $g_{ii'}^{(k')}$ are defined by relations

$$\begin{aligned} f_{ii'}^{(k')} &= -(k'-2)(k'-d) \phi_{ii'}^{(k'-2)} + \sum_{k=2}^{k'} \left(V_{ii}^{(k)} - Z_{i'}^{(k)}\right) \phi_{ii'}^{(k'-k)} \\ &+ \sum_{k=1}^{k'} \left(Z_{i'}^{(k)}(2k'-2-k) \psi_{ii'}^{(k'-k-1)} + \sum_{j=1, j \neq i}^N \left(\sum_{k''=1}^{k'} 2Q_{ij}^{(k)} Z_{i'}^{(k'')} \psi_{ji'}^{(k'-k-k'')}\right.\right. \\ &\left.\left.- 2p_{i'}^2 Q_{ij}^{(k)} \psi_{ji'}^{(k'-k)} + Q_{ij}^{(k)}(-2k'+k+d+1) \phi_{ji'}^{(k'-k-1)} + V_{ij}^{(k)} \phi_{ji'}^{(k'-k)}\right)\right); \\ g_{ii'}^{(k')} &= -(k'-1)(k'-3+d) \psi_{ii'}^{(k'-2)} + \sum_{k=2}^{k'} \left(V_{ii}^{(k)} - Z_{i'}^{(k)}\right) \psi_{ii'}^{(k'-k)} \\ &+ \sum_{j=1, j \neq i}^N \sum_{k=1}^{k'} \left(2Q_{ij}^{(k)} \phi_{ji'}^{(k'-k)} - Q_{ij}^{(k)}(2k'+d-3-k) \psi_{ji'}^{(k'-k-1)} + V_{ij}^{(k)} \psi_{ji'}^{(k'-k)}\right) \end{aligned} \quad (43)$$

with initial conditions $p_{i'}^2 = 2E - \epsilon_{i'}^{(0)}$, $\phi_{ii'}^{(0)} = \delta_{ii'}$, $\psi_{ii'}^{(0)} = 0$, at $i' = i_o$ span over the open channels $i_o = 1, \dots, N_o$ and $p_{i'} = \nu q_{i'}$, $q_{i'} > 0$, $q_{i'}^2 = \epsilon_{i'}^{(0)} - 2E$ at $i' = i_c$ span over the closed channels $i_c = N_o + 1, \dots, N$ that followed from (7) and (17). Also from Eq. (42) at $k' = 1$ and $i = i'$,

$$\left(\epsilon_{i'}^{(1)} - Z_{i'}^{(1)}\right) \phi_{i'i'}^{(0)} = 0, \quad \left(\epsilon_{i'}^{(1)} - Z_{i'}^{(1)}\right) \psi_{i'i'}^{(0)} = 0, \quad (44)$$

we obtain condition $Z_{i'}^{(1)} = \epsilon_{i'}^{(1)}$.

Step 3. Here we perform calculation of the coefficients $\phi_{ii'}^{(k')}$ and $\psi_{ii'}^{(k')}$ by a step-by-step procedure of solving Eqs. (42) for $2E \neq \epsilon_{i'}^{(0)}$, $i \neq i'$ and $k' = 1, \dots, k_{\max}$:

$$\begin{aligned} \phi_{ii'}^{(k')} &= \left[\epsilon_i^{(0)} - \epsilon_{i'}^{(0)}\right]^{-1} \left[-f_{ii'}^{(k')} - \left(\epsilon_i^{(1)} - Z_{i'}^{(1)}\right) \phi_{ii'}^{(k'-1)} + 2p_{i'}^2(k'-1) \psi_{ii'}^{(k'-1)}\right], \\ \psi_{ii'}^{(k')} &= \left[\epsilon_i^{(0)} - \epsilon_{i'}^{(0)}\right]^{-1} \left[-g_{ii'}^{(k')} - 2(k'-1) \phi_{ii'}^{(k'-1)} - \left(\epsilon_i^{(1)} - Z_{i'}^{(1)}\right) \psi_{ii'}^{(k'-1)}\right], \end{aligned} \quad (45)$$

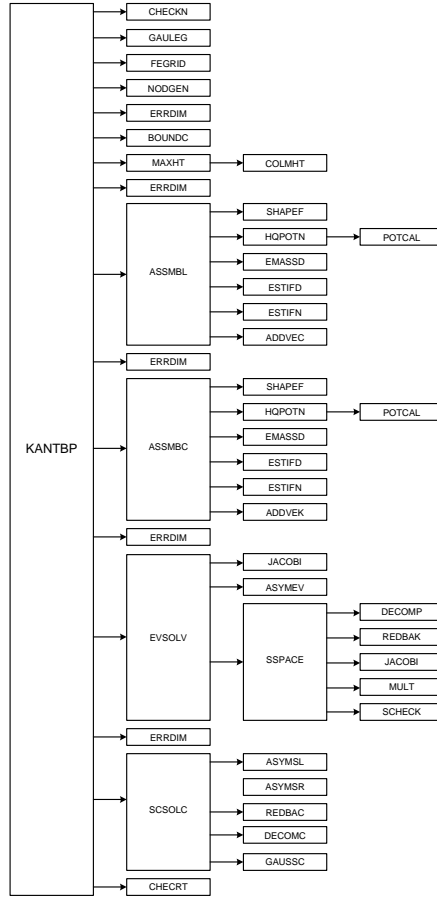

FIG. 2: Flow diagram of the new version of the KANTBP program.

and for $2E \neq \epsilon_{i'}^{(0)}$, $i = i'$ and $k' = 2, \dots, k_{\max}$:

$$\begin{aligned} \phi_{i'i'}^{(k'-1)} &= -[2(k'-1)]^{-1} g_{i'i'}^{(k')}, \\ \psi_{i'i'}^{(k'-1)} &= [2(k'-1) (2E - \epsilon_{i'}^{(0)})]^{-1} f_{i'i'}^{(k')}. \end{aligned} \quad (46)$$

Algorithm described above has been implemented in the MAPLE and FORTRAN (see description of SLAS program in section IV). Resulting **output** provided evaluation of the $\chi_{ji'}(z)$ and $\frac{\chi_{ji'}(z)}{dz}$. This algorithm has been examined with the results from [25].

Remark 2. The choice of appropriate values z_{\min} and z_{\max} for the constructed expansions of the linearly independent solutions for $p_{i_o} > 0$ is controlled by the fulfillment of the Wronskian condition (11), (12)

$$\mathbf{Wr}(\mathbf{Q}(z); \boldsymbol{\chi}^*(z), \boldsymbol{\chi}(z)) = \pm 2i \mathbf{I}_{oo} \quad (47)$$

up to the prescribed precision ε_{W_r} .

III. DESCRIPTION OF THE NEW VERSION OF THE KANTBP PROGRAM

Figure 3 presents a flow diagram for the new version of the KANTBP program. KANTBP program is called from the main routine (supplied by a user) which sets dimensions of the arrays and is responsible for the input data. The KANTBP program needs no installation. The description of all subroutines can be found in comments in the program source code. Also users can find instructions on how to compile the KANTBP in the README file.

The calling sequence for the subroutine KANTBP is:

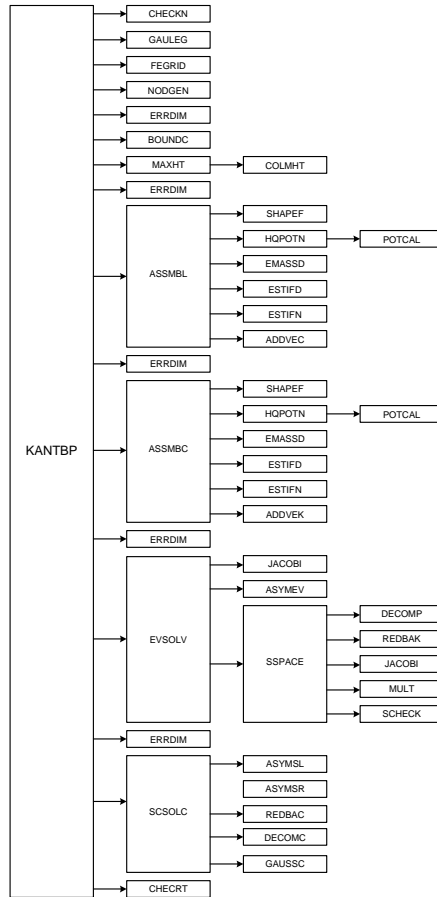

FIG. 3: Flow diagram of the new version of the KANTBP program.

```

CALL KANTBP(TITLE, IPTYPE, ISC, NROOT, MDIM, IDIM, NPOL, RTOL, NITEM,
1      SHIFT, IPRINT, IPRSTP, NMESH, RMESH, NDIR, NDIL, NMDIL,
2      THRSHL, IBOUND, FNOUT, IOUT, POTEN, IOUP, FMATR, IOUM,
3      EVWFN, IOUF, TOT, ITOT, ZTOT, MTOT, MITOT, MZTOT)

```

In the present code each array declarator is written in terms of the symbolic names of constants. These constants are defined in the following PARAMETER statement in the main routine:

```
PARAMETER (MTOT=10000, MITOT=30000, MZTOT=90000, NMESH=7, MDIM=4)
```

Here

- MTOT is the dimension of the working DOUBLE PRECISION array TOT, The last address ILAST of array TOT is calculated and then compared with the given value of MTOT. If $ILAST > MTOT$ the message about an error is printed and the execution of the program is aborted. In the last case, in order to carry out the required calculation it is necessary to increase the dimension MTOT of array TOT to the quantity ILAST taken from the message.
- MITOT is the dimension of the working INTEGER array ITOT. The last address ILAST of array ITOT is calculated and then compared with the given value of MITOT. If $ILAST > MITOT$ the message about an error is printed and the execution of the program is aborted. In the last case, in order to carry out the required calculation it is necessary to increase the dimension MITOT of array ITOT to the quantity ILAST taken from the message.
- MZTOT is the dimension of the DOUBLE COMPLEX working array ZTOT, The last address ILAST of array ZTOT is calculated and then compared with the given value of MZTOT. If $ILAST > MZTOT$ the message about an error is printed and the execution of the program is aborted. In the last case, in order to carry out the required calculation it is necessary to increase the dimension MZTOT of array ZTOT to the quantity ILAST taken from the message.

- NMESH is the dimension of the DOUBLE PRECISION array RMESH containing the information about the subdivision of the longitudinal interval $[z_{\min}, z_{\max}]$ on subintervals and number of elements on each one of them. NMESH is always odd and ≥ 3 .
- MDIM is the dimension of the DOUBLE PRECISION array THRSHL and INTEGER array NDIL containing information about a set of threshold values and numbers of coupled differential equations, respectively.

In order to change the dimensions of the code, all one has to do is to modify the single PARAMETER statement defined above in the main program unit.

We have added a new flag ISC for performing the calculation of the reflection and transmission matrices:

- = 1 – calculation of the reflection and transmission matrices is carried out only with direction $v = \leftarrow$;
- = 2 – calculation of the reflection and transmission matrices is carried out only with direction $v = \rightarrow$;
- = 3 – calculation of the reflection and transmission matrices is carried out with both directions $v = \leftarrow$ and $v = \rightarrow$. Also the properties (IID) of the reflection and transmission matrices are verified.

The meaning of the all arguments except above are presented in [1].

New output data

The results of the calculation of the reflection and transmission matrices and corresponding wave functions are written using unformatted segmented records into file EVWFN, according to the following operator:

```
WRITE(IOUF) NDIM,NN,NOPEN,NGRID,((RR(I,J),I=1,NOPEN),J=1,NOPEN),
1          ((TT(I,J),I=1,NOPEN),J=1,NOPEN),
1          (XGRID(I),I=1,NGRID),((R(I,J),I=1,NN),J=1,NOPEN)
```

In the above, parameters presented in the WRITE statement have the following meaning:

- NDIM is the number of coupled equations,
- NGRID is the number of finite-element grid points,
- NN = NGRID \times NDIM,
- NOPEN is the number of open channels,
- Arrays RR and TT contain the reflection and transmission matrices values calculated,
- Array XGRID contains the values of the finite-element grid points,
- Array R contains NOPEN eigenfunctions each per NN elements in length stored (see the scheme in [1]).

New user-supplied subroutines

- ASYMSL is the name of the new user-supplied subroutine for the scattering problem, $\Phi_{\leftarrow}(z)$, which calculates the regular $\mathbf{X}^{(-)}(z)$, irregular $\mathbf{X}^{(+)}(z)$ asymptotic rectangle-solutions and their derivatives at $z = z_{\max}$, and regular $\mathbf{X}^{(-)}(z)$ asymptotic square-solution and its derivative at $z = z_{\min}$. It should be written as follows:

```
SUBROUTINE ASYMSL(ZMIN,ZMAX,NDIM,NOPEN,QR,SHIFT,THRSHL,
1          PREGL,DREGL,PREGR,PIRRR,DREGR,DIRRR,IOUT)
C . . . . .
C .
C .   P R O G R A M
C .
C .           TO CALCULATE THE REGULAR, IRREGULAR
C .           ASYMPTOTIC MATRIX SOLUTIONS PREGR, PIRRR
C .           AND THEIR DERIVATIVES DREGR, DIRRR AT ZMAX,
C .           THE REGULAR MATRIX SOLUTION PREGL AND ITS
C .           DERIVATIVE DREGL AT ZMIN
C .
C .
C . . . . .
IMPLICIT REAL*8 (A-H,O-Z)
DIMENSION QR(NOPEN),THRSHL(NDIM)
COMPLEX*16 PREGL(NDIM,NDIM),DREGL(NDIM,NDIM),
1          PREGR(NDIM,NOPEN),PIRRR(NDIM,NOPEN),
```

```

1      DREGR (NDIM, NOPEN) , DIRRR (NDIM, NOPEN)
      RETURN
      END

```

- ASYMSR is the name of the new user-supplied subroutine for the scattering problem, $\Phi_{\rightarrow}(z)$, which calculates the regular $\mathbf{X}^{(+)}(z)$, irregular $\mathbf{X}^{(-)}(z)$ asymptotic rectangle-solutions and their derivatives at $z = z_{\min}$, and regular $\mathbf{X}^{(+)}(z)$ asymptotic square-solution and its derivative at $z = z_{\max}$. It should be written as follows:

```

      SUBROUTINE ASYMSR (ZMIN, ZMAX, NDIM, NOPEN, QR, SHIFT, THRSHL,
1      PREGR, DREGR, PREGL, PIRRL, DREGL, DIRRL, IOUT)
C . . . . .
C .
C .   P R O G R A M
C .
C .       TO CALCULATE THE REGULAR, IRREGULAR
C .       ASYMPTOTIC MATRIX SOLUTIONS PREGL, PIRRL
C .       AND THEIR DERIVATIVES DREGL, DIRRL AT ZMIN,
C .       THE REGULAR MATRIX SOLUTION PREGR AND ITS
C .       DERIVATIVE DREGR AT ZMAX
C .
C .
C . . . . .
      IMPLICIT REAL*8 (A-H, O-Z)
      DIMENSION QR (NOPEN) , THRSHL (NDIM)
      COMPLEX*16 PREGR (NDIM, NDIM) , DREGR (NDIM, NDIM) ,
1      PREGL (NDIM, NOPEN) , PIRRL (NDIM, NOPEN) ,
1      DREGL (NDIM, NOPEN) , DIRRL (NDIM, NOPEN)
      RETURN
      END

```

Here arrays QR and THRSHL contain a set of momentum and threshold values, respectively; SHIFT contains the given double energy spectrum value; NDIM is the number of coupled equations; NOPEN is the number of open channels; IOUT is number of the output logical device for printing out the results of the calculation. *To set the third-type boundary conditions at both points $z_{\min} < 0$ and $z_{\max} > 0$, flags IBOUND and IDIM always should be 8 and 1.* Here IBOUND is parameter defining the type of boundary conditions, and IDIM is dimension of the envelope space [1].

A. Description of new subprogram units

The function of each new subroutine is briefly described below. Additional details may be found in COMMENT cards within the program.

- Subroutine ADDVEK assembles the element into the corresponding global complex vector using a compact storage form. This is modified version of subroutine ADDVEC [1] for complex arithmetics.
- Subroutine ASSMBC controls the calculation of element complex stiffness matrix and assembles them into the corresponding global complex matrix. This is modified version of subroutine ASSMBL [1] for complex arithmetics.
- Subroutine CHECRT controls the properties (IID) of calculated reflection \mathbf{R}_{\leftarrow} , \mathbf{R}_{\rightarrow} and transmission \mathbf{T}_{\leftarrow} , \mathbf{T}_{\rightarrow} matrices.
- Subroutine CHECKN prints error messages when input data are incorrect and stops the execution of program KANTBP.
- Subroutine DECOMC calculates $\mathbf{L D L}^T$ factorization of matrix. This factorization is used in subroutine REDBAC to reduce and back-substitute the iteration vectors. They are modified versions of subroutines DECOMP and REDBAK [24] for complex arithmetics.
- Subroutine GAUSSC calculates linear equation solution by the Gauss-Jordan matrix inversion method. This is a modified version of subroutine GAUSSJ [26] for complex arithmetics.

- Subroutine HQPOTN calculates potential matrix elements of coupling in the Gaussian nodes of the finite-element mesh. This is a modified version of subroutine HQPOT [1] which calculates potential matrix elements of coupling in the $z = z_{\min}$.
- Subroutine SCSOLC calculates the reflection and transmission matrices and corresponding wave functions, and writes them into file EVWFN, if necessary.

IV. DESCRIPTION OF THE AUXILIARY SLAS PROGRAM

The calling sequence for the subroutine SLAS is:

```
CALL SLAS(XS,SHIFT,THRSHL,IDIM,NDIM,NOPEN,NMAX,KMAX,
1      MAXZ,ZPREGR,ZDREGR,FXSAS,ZASO)
```

where arguments have the following type and meaning:

Input data

XS	REAL*8	value of z_{\min} or z_{\max} .
SHIFT	REAL*8	the given double energy spectrum.
THRSHL	REAL*8	array THRSHL of dimension NDIM containing values of the thresholds $\epsilon_i^{(0)}$.
IDIM	INTEGER	dimension of the envelope space.
NDIM	INTEGER	number of coupled differential equations.
NOPEN	INTEGER	number of open channels.
NMAX	INTEGER	number of required linear independent solutions and always $NMAX \leq NDIM$.
KMAX	INTEGER	maximal order of asymptotic expansions of matrix elements $\mathbf{V}(z)$ and $\mathbf{Q}(z)$ at large $ z $.
MAXZ	INTEGER	value of k'_{\max} in etalon equation (38).
ZPREGR	COMPLEX*16	array ZPREGR of dimension $NDIM \times NMAX$. In input ZPREGR(I,I) contains value of regular/irregular solution of I-th etalon equation (38), while on output ZPREGR contains asymptotic regular/irregular matrix-solution of Eq. (35).
ZDREGR	COMPLEX*16	array ZDREGR of dimension $NDIM \times NMAX$. On input ZDREGR(I,I) contains first derivative of regular/irregular solution of I-th etalon equation (38), while on output ZDREGR contains first derivative of asymptotic regular/irregular matrix-solution of Eq. (35).
FXSAS	LOGICAL*8	if FXSAS = .TRUE. then calculates only recommended value of boundary points. In othercase calculates ZPREGR and ZDREGR.

- ZASO is the name of the external user-supplied subroutine for evaluating coefficients $Z_i^{(k)}$ of the etalon equation (38), and should be written as follows:

```
      SUBROUTINE ZASO(ZAS,MAXZ,SHIFT,THRSHL,NDIM,NOPEN,ABSB)
C . . . . .
C .
C .   P R O G R A M
C .           TO CALCULATE THE COEFFICIENTS OF ETALON
C .           EQUATION
C .
C .
C . . . . .
      IMPLICIT REAL*8 (A-H,O-Z)
      COMPLEX*16 ZAS(NDIM,MAXZ)
      RETURN
      END
```

- VQAS0 is the name of the new user-supplied subroutine for the evaluate the coefficients $V_{ij}^{(l)}$ ($2 \leq l \leq k_{\max}$) and $Q_{ij}^{(l)}$ ($1 \leq l \leq k_{\max}$) of the asymptotic expansion (36) of matrix element $\mathbf{V}(z)$ and $\mathbf{Q}(z)$ at large $|z|$, and should be written as follows:

```

SUBROUTINE VQAS0(VAS,QAS,KMAX,NDIM,ABSB)
C . . . . .
C .
C .   P R O G R A M
C .           TO CALCULATE THE COEFFICIENTS OF THE ASYMPTOTIC
C .           MATRIX ELEMENTS V(z) and Q(z) WITH ORDER KMAX
C .           AT LARGE |z|
C .
C .
C . . . . .
IMPLICIT REAL*8 (A-H,O-Z)
DIMENSION VAS(NDIM,NDIM,2:KMAX),QAS(NDIM,NDIM,KMAX)
RETURN
END

```

Here as followed from (44), on output ZAS(I,1) should be equal $\epsilon_I^{(1)}$, and on input the parameter ABSB = sign(XS). Subroutine SLAS in program KANTBP, is called as needed via subroutines ASYMSL and ASYMSR.

V. BENCHMARK CALCULATION OF PENETRATION COEFFICIENT

Wave function $\tilde{\Psi}(\tilde{x}, \tilde{y})$ of two particles (or ions) labeled by $i = 1, 2$ connected with oscillator potential penetration through repulsive (Coulomb) barriers $\tilde{U}(\tilde{x}_i)$ in the center-mass-system satisfies the two-dimensional Schrödinger equation [21]:

$$\left(-\frac{\hbar^2}{2M} \frac{\partial^2}{\partial \tilde{y}^2} - \frac{\hbar^2}{2\mu} \frac{\partial^2}{\partial \tilde{x}^2} + \frac{\mu}{2} \tilde{\omega}^2 \tilde{x}^2 + \tilde{U}_1(\tilde{x}_1) + \tilde{U}_2(\tilde{x}_2) - \tilde{E} \right) \tilde{\Psi}(\tilde{x}, \tilde{y}) = 0, \quad (48)$$

where $\tilde{\omega}$ is the oscillator frequency, \tilde{E} is the energy, $\tilde{x}_1 = \tilde{y} + s_1 \tilde{x}$, $\tilde{x}_2 = \tilde{y} - s_3 \tilde{x}$ are variables in the laboratory system of coordinates. The parameters $s_1 = \frac{m_2}{M}$, $s_3 = \frac{m_1}{M}$ are defined via masses of particles m_1 and m_2 , and their total $M = m_1 + m_2$ and reduced $\mu = \frac{m_1 m_2}{M}$ masses.

Using the transformation of variables

$$x = x_{osc}^{-1} \tilde{x}, \quad y = \sqrt{\frac{M}{\mu}} x_{osc}^{-1} \tilde{y}, \quad (49)$$

with the oscillator units of length $x_{osc} = \sqrt{\frac{\hbar}{\mu \tilde{\omega}}}$, the corresponding Eq. (48) leads to the following dimensionless equation

$$\left(-\frac{\partial^2}{\partial y^2} - \frac{\partial^2}{\partial x^2} + x^2 + V(x, y) - \mathcal{E} \right) \Psi(x, y) = 0, \quad (50)$$

where $\mathcal{E} \equiv 2E = \frac{\tilde{E}}{E_{osc}}$ and $V(x, y)$ are the dimensionless energy and barrier potential in units of energy $E_{osc} = \frac{\hbar \tilde{\omega}}{2}$

$$V(x, y) = U_1(x_1) + U_2(x_2) \equiv \frac{1}{E_{osc}} \left(\tilde{U}_1(\tilde{x}_1) + \tilde{U}_2(\tilde{x}_2) \right). \quad (51)$$

where $x_1 = s_2 y + s_1 x$ and $x_2 = s_2 y - s_3 x$ with $s_2 = \sqrt{\frac{\mu}{M}}$.

Model A. We choose barrier potentials $U_i(x_i)$ with effective charges $\hat{Z}_i > 0$ in the form of the repulsive truncated Coulomb potential cut off on small $0 < \bar{x}_{\min} < 1$ and large $\bar{x}_{\max} > 1$ distances from $x_i = 0$ as [18, 19]

$$U_i(x_i) = \begin{cases} \frac{2\hat{Z}_i}{\bar{x}_{\min}} - \frac{2\hat{Z}_i}{\bar{x}_{\max}}, & |x_i| \leq \bar{x}_{\min}, \\ \frac{2\hat{Z}_i}{|x_i|} - \frac{2\hat{Z}_i}{\bar{x}_{\max}}, & \bar{x}_{\min} < |x_i| \leq \bar{x}_{\max}, \\ 0, & |x_i| > \bar{x}_{\max}. \end{cases} \quad (52)$$

Model B. We define the Coulomb-like potentials $U_i(x_i)$ that depend on the integer parameter $s \geq 2$ and truncation parameter $\bar{x}_{\min} > 0$ [21]:

$$U_i(x_i) = \frac{2\hat{Z}_i}{\sqrt[s]{|x_i|^s + \bar{x}_{\min}^s}}. \quad (53)$$

The asymptotic boundary conditions for the solution $\Psi(y, x) = \{\Psi_{i_o}(y, x)\}_{i_o=1}^{N_o}$ with direction $v \Rightarrow$ can be written in the obvious form

$$\begin{aligned} \Psi_{i_o}(y \rightarrow -\infty, x) &\rightarrow B_{i_o}^{(0)}(x) \frac{\exp\left(i\left(p_{i_o}y - \text{sign}(y)\frac{Z_{12}}{p_{i_o}} \ln(2p_{i_o}|y|)\right)\right)}{\sqrt{p_{i_o}}} \\ &+ \sum_{j=1}^{N_o} B_j^{(0)}(x) \frac{\exp\left(-i\left(p_jy - \text{sign}(y)\frac{Z_{12}}{p_j} \ln(2p_j|y|)\right)\right)}{\sqrt{p_j}} R_{j i_o}, \\ \Psi_{i_o}(y \rightarrow +\infty, x) &\rightarrow \sum_{j=1}^{N_o} B_j^{(0)}(x) \frac{\exp\left(i\left(p_jy - \text{sign}(y)\frac{Z_{12}}{p_j} \ln(2p_j|y|)\right)\right)}{\sqrt{p_j}} T_{j i_o}, \\ \Psi_{i_o}(y, x \rightarrow \pm\infty) &\rightarrow 0. \end{aligned} \quad (54)$$

Here N_o is the number of open channels at fixed energy $2E = p^2 + \varepsilon_{i_o}^{(0)} > 0$; $Z_{12} = 0$ for *model A* and $Z_{12} = (\hat{Z}_1 + \hat{Z}_2)/s_2$ for *model B*; $R_{j i_o}$ and $T_{j i_o}$ are unknown reflection and transmission amplitudes; $B_j^{(0)}(x)$ are the basis functions of oscillator corresponding to energy $\varepsilon_j^{(0)} = 2j - 1$ at $j \geq 1$

$$\left(-\frac{\partial^2}{\partial x^2} + x^2 - \varepsilon_j^{(0)}\right) B_j^{(0)}(x) = 0, \quad \int_{-\infty}^{+\infty} B_i^{(0)}(x) B_j^{(0)}(x) dx = \delta_{ij}. \quad (55)$$

A. Kantorovich expansion

We construct a desired solution of the boundary-value problem (BVP) (50), (54) in the form of Kantorovich expansion:

$$\Psi_{i'}(x, y) = \sum_{j=1}^N B_j(x; y) \chi_{j i'}(y). \quad (56)$$

The basis functions $B_j(x; y)$ in the fast variable x and the potential curves $\varepsilon_j(y)$ that depend continuously on slow variable y as a parameter are chosen as solutions of the BVPs for the equation on grid $\Omega_x\{x_{\min}(y), x_{\max}(y)\}$

$$\left(-\frac{d^2}{dx^2} + x^2 + V(x, y) - \varepsilon_j(y)\right) B_j(x; y) = 0, \quad (57)$$

which are subject to the boundary, normalization and orthogonality conditions

$$\begin{aligned} B_j(x_{\min}(y); y) &= B_j(x_{\max}(y); y) = 0, \\ \int_{x_{\min}(y)}^{x_{\max}(y)} B_i(x; y) B_j(x; y) dx &= \delta_{ij}. \end{aligned} \quad (58)$$

By substituting (56) into (50), (54) and by taking average over (58), we obtain the BVP for a set of N coupled ODEs that describes the slow subsystem for the partial solutions $\boldsymbol{\chi}^{(j)}(y) = \left(\chi_1^{(j)}(y), \dots, \chi_N^{(j)}(y)\right)^T$:

$$\left(-\mathbf{I} \frac{d^2}{dy^2} + \mathbf{V}(y) + \mathbf{Q}(y) \frac{d}{dy} + \frac{d\mathbf{Q}(y)}{dy} - 2E\mathbf{I}\right) \boldsymbol{\chi}^{(j)}(y) = 0. \quad (59)$$

Here \mathbf{I} is the unit $N \times N$ matrix, $\mathbf{V}(y)$ and $\mathbf{Q}(y)$ are the effective potential $N \times N$ matrices:

$$V_{ij}(y) = \varepsilon_j(y)\delta_{ij} + \int_{x_{\min}(y)}^{x_{\max}(y)} \frac{\partial B_i(x; y)}{\partial y} \frac{\partial B_j(x; y)}{\partial y} dx, \quad (60)$$

$$Q_{ij}(y) = - \int_{x_{\min}(y)}^{x_{\max}(y)} B_i(x; y) \frac{\partial B_j(x; y)}{\partial y} dx.$$

The eigenvalue problem (57), (58) was solved by the ODPEVP program [27] for $y \in [y_{\min}, y_{\max}]$ good separated eigenvalues $|\varepsilon_i(y) - \varepsilon_{i-1}(y)| > \epsilon > 0$ where $\epsilon \sim 0.05$ for the double precision arithmetic. This condition is valid for accepted values of parameters of considered models. In the case of non-good separated eigenvalues, i.e. if $0 < |\varepsilon_i(y_*) - \varepsilon_{i-1}(y_*)| \leq \epsilon$, one should generate a more dense grid in vicinity $v_y = |y - y_*| < \epsilon_*$ of avoided crossing points y_* and/or use multi-precision arithmetic. For long-range potentials one should construct appropriate asymptotic expansion for eigenvalues and corresponding eigenfunctions $y \in (-\infty, +\infty) \setminus [y_{\min}, y_{\max}]$ to build up asymptotic effective potentials with leading terms

$$V_{ij}(y) = \left(\varepsilon_j^{(0)} + \text{sign}(y) \frac{2Z_{12}}{y} \right) \delta_{ij} + \sum_{k=3}^{k_{\max}} \frac{V_{ij}^{(k, \pm)}}{y^k} + O(y^{-k_{\max}-1}),$$

$$Q_{ij}(y) = \sum_{k=3}^{k_{\max}} \frac{Q_{ij}^{(k, \pm)}}{y^k} + O(y^{-k_{\max}-1}), \quad (61)$$

where the sign “+” is for $y > 0$ and “-” is for $y < 0$.

For given number N of Eq. (59), the values x_{\min} and x_{\max} of grid $\Omega_x \{x_{\min}, x_{\max}\}$ were chosen in the region $|x| > x_0 = \sqrt{2N-1}$, where the Hermite polynomial [29] (or basis function $B_j(x; y)$ in a general case) has no zeros. These values are computed with prescribed precision $eps > 0$ from the condition

$$\exp\left(-\int_{x_0}^x dx \sqrt{x^2 - x_0^2}\right) \leq eps, \quad (62)$$

which in the given case leads to inequality

$$\exp\left(-x\sqrt{x^2 - x_0^2}/2\right) \left(x + \sqrt{x^2 - x_0^2}\right)^{x_0^2/2} x_0^{-x_0^2/2} \leq eps. \quad (63)$$

To find an approximate solution, at the first step we choose initial approximation $x_{\max} = x_0$, after which it is increased with step 1 until condition (63) is satisfied. Values $y_{\min} < x_{\min}$ and $y_{\max} > x_{\max}$ were chosen from the condition that potential (53) is negligible on the interval $x_{\min} < x < x_{\max}$.

The matching points y_1^{match} and y_2^{match} of the numerical (60) and asymptotic (61) effective potential were calculated as follows:

$$y_1^{match} = \min\left(y_-^Q, y_-^V\right), \quad y_2^{match} = \max\left(y_+^Q, y_+^V\right), \quad (64)$$

$$y_{\pm}^Q = \pm \sqrt[k_{\max}]{\frac{|Q_{NN-1}^{(k_{\max}, \pm)}|}{eps}}, \quad y_{\pm}^V = \pm \sqrt[k_{\max}]{\frac{|V_{NN}^{(k_{\max}, \pm)}|}{eps}},$$

since $|Q_{ij}^{(k_{\max}, \pm)}| < |Q_{NN-1}^{(k_{\max}, \pm)}|$, $|V_{ij}^{(k_{\max}, \pm)}| < |V_{NN}^{(k_{\max}, \pm)}|$. The values y_{\min} and y_{\max} were satisfied by inequalities $y_{\min} < y_1^{match} < x_{\min}$ and $y_{\max} > y_2^{match} > x_{\max}$ that should be calculated from conditions

$$y_{\min} = \min \left[y_1^{match}, \min_{j, i_0} \left(- \sqrt[k_{\max}]{\frac{|\phi_{j i_0}^{(k_{\max}, -)}|}{eps}} \right), \min_{j, i_0} \left(- \sqrt[k_{\max}]{\frac{|\psi_{j i_0}^{(k_{\max}, -)}|}{eps}} \right) \right],$$

$$y_{\max} = \max \left[y_2^{match}, \max_{j, i_0} \left(\sqrt[k_{\max}]{\frac{|\phi_{j i_0}^{(k_{\max}, +)}|}{eps}} \right), \max_{j, i_0} \left(\sqrt[k_{\max}]{\frac{|\psi_{j i_0}^{(k_{\max}, +)}|}{eps}} \right) \right]. \quad (65)$$

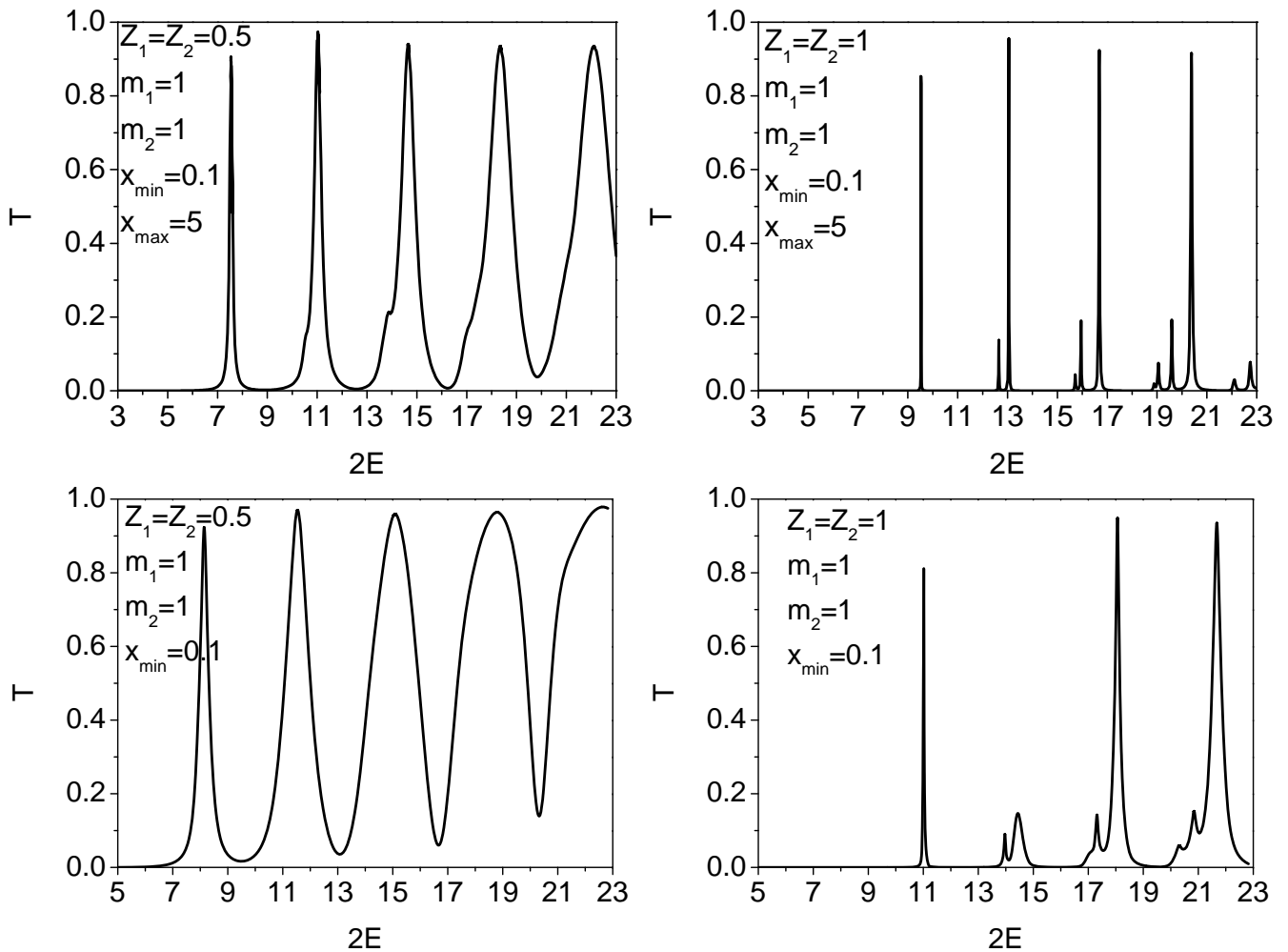

FIG. 4: The total probabilities $P \equiv \bar{T}_{11}$ of penetration vs energy $\mathcal{E} = 2E$ through truncated Coulomb (52) (upper panel) and Coulomb-like (53) (lower panel) potential barriers.

For the calculation of asymptotic solutions of *model B*, we have used etalon equation (38) at $d = 1$, $k'_{\max} = 1$ and $Z_{i'}^{(1)} = 2\text{sign}(y)Z_{12}$, which corresponds to known solutions in the open channels

$$R_{i_o}^{\pm}(p_{i_o}, y) = p_{i_o}^{-1/2} \begin{cases} (G_0(p_{i_o}, +y) \pm \imath F_0(p_{i_o}, +y)) \exp(\mp \imath \delta_{i_o})/2, & y > 0, \\ (G_0(p_{i_o}, -y) \mp \imath F_0(p_{i_o}, -y)) \exp(\pm \imath \delta_{i_o})/2, & y < 0, \end{cases} \quad (66)$$

and in the closed channels

$$R_{i_c}(q_{i_c}, y) = q_{i_c}^{-1/2} t \exp(-t/2) U(1 + Z_{12}/q_{i_c}, 2, t), \quad t = 2q_{i_c}|y|. \quad (67)$$

Here $F_0(p_{i_o}, y)$ and $G_0(p_{i_o}, y)$ are the regular and irregular continuum zero order Coulomb functions calculated by subroutine RCWFNN [25] which is a modified version of the subroutine RCWFN [28] for the DOUBLE PRECISION accuracy, $\sigma_{i_o} = \arg \Gamma(1 + \imath Z_{12}/p_{i_o})$ is the Coulomb phase shift [29], and $U(a, b, c)$ is the confluent hypergeometric function of second kind calculated by subroutine CHGU [30]. *Note that, for the numerical calculation we have neglected the exponentially small factor $\exp(-t/2)$ in $R_{i_c}(q_{i_c}, y)$ and its first derivative, since this factor is canceled during evaluation of $\mathcal{R}(y)$ matrix in Eq. (18).* The coefficients $V_{ij}^{(k, \pm)}$, $V_{ij}^{(k, \pm)}$, $\phi_{ji}^{(k, \pm)}$ and $\psi_{ji}^{(k, \pm)}$ have been implemented in MAPLE and FORTRAN up to order $k_{\max} = 11$ using an algorithm described in [21] and Section IID.

Below we have used values of parameters: $m_1 = m_2 = 1$, $\bar{x}_{\min} = 0.1$, $\hat{Z}_1 = \hat{Z}_2 = 0.5$ and $\hat{Z}_1 = \hat{Z}_2 = 1$. Also $\bar{x}_{\max} = 5$ for *model A*, and $s = 8$ for *model B*. In the considered examples we used grids $\Omega_x\{x_{\min}, x_{\max}\} = \{-10(768)10\}$ and $\Omega_y\{y_{\min}, y_{\max}\} = \{-125(200) - 25(100) - 6(200)6(100)25(200)125\}$ with the Lagrange elements of the order $p = 4$

between the nodes. In the above, the number of grid elements for grids Ω_x and Ω_y is shown in the parentheses. At the boundary points y_{\min} and y_{\max} the absolute accuracy ε_{W_r} of calculated Wronskian (12) was less than 10^{-11} .

The total probabilities $P \equiv \bar{T}_{11} = \sum_{j=1}^{N_o} |T_{1j}|^2$ of penetration through truncated Coulomb (52) and Coulomb-like (53) potential barriers of *models A and B* are shown in Figure 4. These pictures illustrate the important peculiarity that a more realistic nontruncated Coulomb-like barrier, being more wide than truncated one, leads to a set of the probability maximums having a bigger half-width. It can be used for verification of the *models of type A and B* and quantum transparency effect.

VI. TEST DESK

We consider the BVP (50) with parameters $m_1 = 1$, $m_2 = 3$, $\bar{x}_{\min} = 0.1$, $Z_1 = Z_2 = 0.1$, $s = 8$ and $N = 4$. The corresponding BVP (??) and the matrix elements $\mathbf{V}(z)$, $\mathbf{Q}(z)$ have been solved on grid $\Omega_x\{x_{\min}, x_{\max}\} = \{-x_{\min}(64)x_{\max}\}$ with accuracy 10^{-10} . Boundary points $x_{\max} = -x_{\min} \approx 8.8$ were defined by the inequality (63). All calculation details of this problem were written into file ODPEVP.LPR.

The following values of numerical parameters and characters have been used in the test run via the supplied input file SQRTBT.INP:

```
&PARAS TITLE=' REFLECTION AND TRANSMISSION MATRICES ',
      IPTYPE=1,ISC=3,IDIM=1,NPOL=4,
      SHIFT= 4D0,IPRINT=1,IPRSTP=120,
      RMESH=-25D0,100D0,-6D0,100D0,6D0,100D0,25D0,
      NDIR=1, NDIL=4, NMDIL=1,THRSHL= 1.D0,3D0,5D0,7D0,IBOUND=8,
      FNOUT='KANTBP.LPR',IOUT=7,POTEN='ODPEVP.PTN',IOUP=10,
      FMATR='KANTBP.MAT',IOUM=11,EVWFN='KANTBP.WFN',IOUF=0
&END
```

Acknowledgments

Authors thank Prof. F.M. Pen'kov and Dr. P.M. Krassovitskiy for collaboration in the field. A.A.G., O.C. and S.I.V. acknowledge financial support from RFBR Grants Nos. 11-01-00523 and 10-01-00200, and the theme 09-6-1060-2005/2013 "Mathematical support of experimental and theoretical studies conducted by JINR".

TEST RUN OUTPUT

```
PROBLEM: REFLECTION AND TRANSMISSION MATRICES
*****
```

CONTROL INFORMATION

```
-----
NUMBER OF DIFFERENTIAL EQUATIONS. . . . . (MDIM ) =    4
NUMBER OF FINITE ELEMENTS . . . . . (NELEM ) =   300
NUMBER OF GRID POINTS . . . . . (NGRID ) =  1201
ORDER OF SHAPE FUNCTIONS. . . . . (NPOL ) =    4
ORDER OF GAUSS-LEGENDRE QUADRATURE. . . . (NGQ ) =    5
DIMENSION OF ENVELOPE SPACE . . . . . (IDIM ) =    1
BOUNDARY CONDITION CODE . . . . . (IBOUND) =    8
DOUBLE ENERGY SPECTRUM. . . . . (SHIFT ) =  4.00000
```

```
SUBDIVISION OF RHO-REGION ON THE FINITE-ELEMENT GROUPS:
*****
```

NO OF GROUP	NUMBER OF ELEMENTS	BEGIN OF INTERVAL	LENGTH OF ELEMENT	GRID STEP	END OF INTERVAL
1	100	-25.000	0.19000	0.04750	-6.000
2	100	-6.000	0.12000	0.03000	6.000
3	100	6.000	0.19000	0.04750	25.000

```
*****
```

```
NDIM, MDIM=      4      4
```

T O T A L S Y S T E M D A T A

TOTAL NUMBER OF ALGEBRAIC EQUATIONS. . . . (NN) = 4804
TOTAL NUMBER OF MATRIX ELEMENTS. (NWK) = 60010
MAXIMUM HALF BANDWIDTH (MK) = 20
MEAN HALF BANDWIDTH (MMK) = 12

CALCULATION OF WAVE FUNCTION WITH DIRECTION <--

NUMBER OF OPEN CHANNELS. (NOPEN) = 2
VALUE OF I-TH MOMENTUM (I,QR) = 1 0.1732E+01
VALUE OF I-TH MOMENTUM (I,QR) = 2 0.1000E+01

I M P A R T O F W R O N S K I A N

-2.00000 -.179667E-08
-.179667E-08 -2.00000

R E P A R T O F R R M A T R I X

-.194759 -.591176E-03
-.591176E-03 -.485403E-01

I M P A R T O F R R M A T R I X

-.124681 0.172716
0.172716 0.931470

R E P A R T O F T T M A T R I X

0.600459 -.317926E-01
0.317926E-01 -.276469

I M P A R T O F T T M A T R I X

-.729781 0.150167
-.150167 0.134574E-01

Z R E P A R T O F F U N C T I O N S

-25.0000 0.6664D+00 -.1165D+00 0.1531D+00 -.1120D+00 0.7601D-06 0.8680D-05 0.2445D-07 0.4751D-06
-19.3000 -.7209D+00 0.1045D+00 0.1325D+00 0.8070D-01 -.5930D-05 0.2169D-04 -.4531D-06 0.1458D-05
-13.6000 0.6802D+00 -.7978D-01 0.4223D-01 0.2431D+00 -.2701D-04 0.3867D-04 -.2948D-05 0.3128D-05
-7.9000 -.5802D+00 0.5077D-01 -.8674D-01 0.2719D+00 -.4534D-03 0.2169D-03 -.6446D-04 -.1879D-04
-3.6000 0.1490D-01 -.5461D-01 -.3718D-01 -.2780D+00 -.9231D-02 0.2399D-02 -.1300D-02 -.2460D-03
0.0000 -.8416D+00 0.7861D-01 0.9335D-02 0.4446D+00 0.5112D-01 -.1732D-01 -.2248D-02 -.6851D-02
3.6000 -.4115D+00 -.6691D-01 0.8351D-01 0.1351D+01 -.4633D-02 0.2046D-01 -.2638D-04 -.7678D-04
7.9000 -.6232D+00 0.3071D-01 0.6435D-01 -.5763D+00 -.3348D-03 -.1124D-02 0.5789D-04 0.3906D-03
13.6000 0.5769D+00 -.6829D-01 -.8088D-01 -.1298D+01 -.3777D-04 -.5932D-04 0.3999D-05 0.9632D-05
19.3000 -.4592D+00 0.1030D+00 -.1646D+00 -.1211D+01 -.1728D-05 0.5374D-04 0.2039D-06 -.3182D-05
25.0000 0.2716D+00 -.1259D+00 -.1631D+00 -.5370D+00 0.1506D-05 0.4406D-04 -.6915D-07 -.2284D-05

Z I M P A R T O F F U N C T I O N S

-25.0000 0.2735D+00 0.1055D-01 -.2391D-01 -.2560D+00 0.6563D-05 -.4645D-05 0.3403D-06 -.2162D-06
-19.3000 -.7902D-02 -.5291D-01 0.8108D-01 -.2684D+00 0.7047D-05 0.5197D-05 0.4906D-06 0.4708D-06
-13.6000 -.2428D+00 0.8603D-01 0.1506D+00 -.1425D+00 0.2784D-04 0.5248D-04 0.2187D-05 0.5597D-05
-7.9000 0.4353D+00 -.1061D+00 0.1328D+00 0.8857D-01 -.1206D-03 0.5087D-03 -.4282D-04 0.9200D-04
-3.6000 0.7372D+00 -.1083D+00 -.1518D+00 0.1221D+00 0.1107D-02 -.5540D-02 -.1591D-02 -.3790D-03
0.0000 0.5262D+00 -.1487D+00 -.1846D-01 0.6235D+00 -.3506D-01 -.4285D-03 -.5965D-02 -.9390D-02
3.6000 -.5284D+00 -.8130D-01 0.1780D+00 0.1380D+01 0.1289D-01 0.1935D-01 -.2316D-02 0.6339D-04
7.9000 0.3095D+00 -.1298D+00 -.1677D+00 -.5138D+00 0.3710D-03 -.1388D-02 -.1535D-04 0.4310D-03
13.6000 -.5507D+00 0.1129D+00 -.1559D+00 -.1335D+01 0.6059D-05 -.8405D-04 -.3894D-06 0.1222D-04
19.3000 0.7698D+00 -.8224D-01 -.5905D-01 -.1316D+01 0.1620D-04 0.4979D-04 -.1052D-05 -.2867D-05
25.0000 -.8982D+00 0.3837D-01 0.6149D-01 -.6546D+00 0.5103D-05 0.4498D-04 -.2851D-06 -.2320D-05

CALCULATION OF WAVE FUNCTION WITH DIRECTION -->

NUMBER OF OPEN CHANNELS. (NOPEN) = 2
VALUE OF I-TH MOMENTUM (I,QR) = 1 0.1732E+01
VALUE OF I-TH MOMENTUM (I,QR) = 2 0.1000E+01

I M P A R T O F W R O N S K I A N

 2.00000 -.179667E-08
 -.179667E-08 2.00000

REPART OF RR MATRIX

 -.194759 0.591176E-03
 0.591176E-03 -.485403E-01

IMPART OF RR MATRIX

 -.124681 -.172716
 -.172716 0.931470

REPART OF TT MATRIX

 0.600459 0.317926E-01
 -.317926E-01 -.276469

IMPART OF TT MATRIX

 -.729781 -.150167
 0.150167 0.134574E-01

Z REPART OF FUNCTIONS

 -25.0000 0.2716D+00 0.1259D+00 0.1631D+00 -.5370D+00 0.1506D-05 -.4406D-04 0.6915D-07 -.2284D-05
 -19.3000 -.4592D+00 -.1030D+00 0.1646D+00 -.1211D+01 -.1728D-05 -.5374D-04 -.2039D-06 -.3182D-05
 -13.6000 0.5769D+00 0.6829D-01 0.8088D-01 -.1298D+01 -.3777D-04 0.5932D-04 -.3999D-05 0.9632D-05
 -7.9000 -.6232D+00 -.3071D-01 -.6435D-01 -.5763D+00 -.3348D-03 0.1124D-02 -.5789D-04 0.3906D-03
 -3.6000 -.4115D+00 0.6691D-01 -.8351D-01 0.1351D+01 -.4633D-02 -.2046D-01 0.2638D-04 -.7678D-04
 0.0000 -.8416D+00 -.7861D-01 -.9335D-02 0.4446D+00 0.5112D-01 0.1732D-01 0.2248D-02 -.6851D-02
 3.6000 0.1490D-01 0.5461D-01 0.3718D-01 -.2780D+00 -.9231D-02 -.2399D-02 0.1300D-02 -.2460D-03
 7.9000 -.5802D+00 -.5077D-01 0.8674D-01 0.2719D+00 -.4534D-03 -.2169D-03 0.6446D-04 -.1879D-04
 13.6000 0.6802D+00 0.7978D-01 -.4223D-01 0.2431D+00 -.2701D-04 -.3867D-04 0.2948D-05 0.3128D-05
 19.3000 -.7209D+00 -.1045D+00 -.1325D+00 0.8070D-01 -.5930D-05 -.2169D-04 0.4531D-06 0.1458D-05
 25.0000 0.6664D+00 0.1165D+00 -.1531D+00 -.1120D+00 0.7601D-06 -.8680D-05 -.2445D-07 0.4751D-06

Z IMPART OF FUNCTIONS

 -25.0000 -.8982D+00 -.3837D-01 -.6149D-01 -.6546D+00 0.5103D-05 -.4498D-04 0.2851D-06 -.2320D-05
 -19.3000 0.7698D+00 0.8224D-01 0.5905D-01 -.1316D+01 0.1620D-04 -.4979D-04 0.1052D-05 -.2867D-05
 -13.6000 -.5507D+00 -.1129D+00 0.1559D+00 -.1335D+01 0.6059D-05 0.8405D-04 0.3894D-06 0.1222D-04
 -7.9000 0.3095D+00 0.1298D+00 0.1677D+00 -.5138D+00 0.3710D-03 0.1388D-02 0.1535D-04 0.4310D-03
 -3.6000 -.5284D+00 0.8130D-01 -.1780D+00 0.1380D+01 0.1289D-01 -.1935D-01 0.2316D-02 0.6339D-04
 0.0000 0.5262D+00 0.1487D+00 0.1846D-01 0.6235D+00 -.3506D-01 0.4285D-03 0.5965D-02 -.9390D-02
 3.6000 0.7372D+00 0.1083D+00 0.1518D+00 0.1221D+00 0.1107D-02 0.5540D-02 0.1591D-02 -.3790D-03
 7.9000 0.4353D+00 0.1061D+00 -.1328D+00 0.8857D-01 -.1206D-03 -.5087D-03 0.4282D-04 0.9200D-04
 13.6000 -.2428D+00 -.8603D-01 -.1506D+00 -.1425D+00 0.2784D-04 -.5248D-04 -.2187D-05 0.5597D-05
 19.3000 -.7902D-02 0.5291D-01 -.8108D-01 -.2684D+00 0.7047D-05 -.5197D-05 -.4906D-06 0.4708D-06
 25.0000 0.2735D+00 -.1055D-01 0.2391D-01 -.2560D+00 0.6563D-05 0.4645D-05 -.3403D-06 -.2162D-06

CHECK PROPERTIES

 $|RR_{<}|^2 + |TT_{<}|^2$

 1.00000 0.353866E-09
 0.353866E-09 1.00000

MAXIMAL ABSOLUTE ERROR =0.457613E-09

 $|RR_{>}|^2 + |TT_{>}|^2$

 1.00000 -.353867E-09
 -.353867E-09 1.00000

MAXIMAL ABSOLUTE ERROR =0.457614E-09

 REPART: $TT_{>}^* RR_{<} + RR_{>}^* TT_{<}$

 0.179243E-09 0.475463E-09
 -.475400E-09 0.169614E-09

 IMPART: $TT_{>}^* RR_{<} + RR_{>}^* TT_{<}$

 0.367987E-13 -.198433E-09

```

-.198434E-09 -.320299E-13
M A X I M A L A B S O L U T E E R R O R =0.515210E-09
R E P A R T: RR_<-~T - RR_<-
-----
0.00000 -.128480E-09
0.128480E-09 0.00000
I M P A R T: RR_<-~T - RR_<-
-----
0.00000 0.472197E-09
-.472197E-09 0.00000
M A X I M A L A B S O L U T E E R R O R =0.489364E-09
R E P A R T: RR_>~T - RR_>
-----
0.00000 0.128480E-09
-.128480E-09 0.00000
I M P A R T: RR_>~T - RR_>
-----
0.00000 -.472197E-09
0.472197E-09 0.00000
M A X I M A L A B S O L U T E E R R O R =0.489364E-09
R E P A R T: TT_>~T - TT_<-
-----
0.258571E-12 -.318056E-11
-.309714E-11 -.360267E-13
I M P A R T: TT_>~T - TT_<-
-----
0.251799E-12 0.511789E-09
0.511769E-09 -.207664E-13
M A X I M A L A B S O L U T E E R R O R =0.511799E-09

```

-
- [1] O. Chuluunbaatar, A.A. Gusev, A.G. Abrashkevich, A. Amaya-Tapia, M.S. Kaschiev, S.Y. Larsen and S.I. Vinitzky, *Comput. Phys. Commun.* 177 (2007) 649–675.
- [2] O. Chuluunbaatar, A.A. Gusev, S.I. Vinitzky and A.G. Abrashkevich, *Comput. Phys. Commun.* 179 (2008) 685–693.
- [3] H.J. Assenbaum, K. Langanke and C. Rolfs, *Z. Phys. A* 327 (1987) 461–468.
- [4] L. Bracci, G. Fiorentini, V.S. Melezhik, G. Mezzorani and P. Pasini, *Phys. Lett. A* 153 (1991) 456–460.
- [5] V. Melezhik, *Nucl. Phys. A* 550 (1992) 223–234.
- [6] V. Bystritskii et al, *Physics of Atomic Nuclei* 64 (2001) 855–860.
- [7] Yu.N. Demkov and J.D. Meyer, *Eur. Phys. J. B* 42 (2004) 361–365.
- [8] P.M. Krassovitskiy and N.Zh. Takibaev, *Izvestiya RAN, seriya Fizicheskaya*, 70 (2006) 709–712 (in Russian).
- [9] O. Chuluunbaatar, A.A. Gusev, V.L. Derbov, M.S. Kaschiev, L.A. Melnikov, V.V. Serov and S.I. Vinitzky, *J. Phys. A* 40 (2007) 11485–11524.
- [10] O. Chuluunbaatar, A. Gusev, V. Gerdt, M. Kaschiev, V. Rostovtsev, V. Samoylov, T. Tupikova and S. Vinitzky, *Lect. Notes Comp. Sci.* 4770 (2007) 118–133.
- [11] H. Voss, *Comp. Phys. Comm.* 174 (2006) 441–446.
- [12] W. Wang, T.-M. Hwang, J.-C. Jang, *Comp. Phys. Comm.* 174 (2006) 371–385.
- [13] A.A. Gusev, O. Chuluunbaatar, S.I. Vinitzky, E.M. Kazaryan, H. A. Sarkisyan, *J. Phys. Conf. Ser.* 248 (2010) 012047–1–8.
- [14] A.A. Gusev, O. Chuluunbaatar, V.P. Gerdt, V.A. Rostovtsev, S.I. Vinitzky, V.L. Derbov, V.V. Serov, *Lect. Notes Comp. Sci.* 6244 (2010) 106–122.
- [15] J.I. Kim, V.S. Melezhik and P. Schmelcher, *Phys. Rev. Lett.* 97 (2006) 193203–1–4.
- [16] H. Hofmann, *Nucl. Phys. A* 224 (1974) 116–139.
- [17] P. Ring, H. Massmann, and J.O. Rasmussen, *Nucl. Phys. A* 296 (1978) 50–76.
- [18] F.M. Pen'kov, *Phys. Rev A* 62 (2000) 044701–1–4.
- [19] F.M. Pen'kov, *JETP* 91 (2000) 698–705.
- [20] G.L. Goodvin and M.R.A. Shegelski, *Phys. Rev. A* 72 (2005) 042713–1–7.
- [21] A.A. Gusev, S.I. Vinitzky, O. Chuluunbaatar, V.P. Gerdt, V.A. Rostovtsev, *Lecture Notes in Computer Science* 6885 (2011) 175–191.
- [22] L.V. Kantorovich and V.I. Krylov, *Approximate Methods of Higher Analysis*, Wiley, New York, 1964.

- [23] J. Macek, Phys. Rev. A 30 (1984) 1277–1278.
- [24] K.J. Bathe, Finite Element Procedures in Engineering Analysis, Englewood Cliffs, Prentice Hall, New York, 1982.
- [25] O. Chuluunbaatar, A.A. Gusev, V.P. Gerdt, V.A. Rostovtsev, S.I. Vinitzky, A.G. Abrashkevich, M.S. Kaschiev and V.V. Serov, Comput. Phys. Commun. 178 (2007) 301–330.
- [26] W.H. Press, S.A. Teukolsky, W.T. Vetterling and B.P. Flannery, Numerical Recipes: The Art of Scientific Computing, Cambridge University Press, Cambridge, 1986.
- [27] O. Chuluunbaatar, A.A. Gusev, S.I. Vinitzky and A.G. Abrashkevich, Comput. Phys. Commun. 180 (2009) 1358–1375.
- [28] A.R. Barnett, D.H. Feng, J.W. Steed, L.J.B. Goldfarb, Comput. Phys. Comm. 8 (1974) 377–395.
- [29] M. Abramowitz, I.A. Stegun, Handbook of Mathematical Functions, Dover, New York, 1965.
- [30] FORTRAN routines for computation of Special Functions, <http://jin.ece.illinois.edu/routines/routines.html>