

EXPERIMENTAL FACILITIES FOR THE TRD/ALICE TESTS WITH ELECTRON–PION BEAM AND COSMIC PARTICLES

*L. G. Efimov, E. M. Kislov, N. S. Moroz, Yu. A. Panebrattsev,
V. I. Yurevich, A. N. Zubarev*

Joint Institute for Nuclear Research, Dubna

Two special experimental facilities have been designed and produced to provide charged particle tests of the Transition Radiation Detector (TRD) prototypes and modules for the ALICE experiment at CERN. The first facility, comprising the scintillation and Cherenkov detectors, was applied for the TRD elements investigation with a secondary mixed electron–pion beam of the CERN proton synchrotron PS. The second one, consisting of two large-scale scintillation planes and original electronics, is under operation to trigger the 7-m long TRD supermodules on closing stand-alone trial with cosmic particles. The design and performance of both facilities are considered.

Спроектированы и изготовлены две специальные экспериментальные установки, обеспечивающие испытания с заряженными частицами прототипов и модулей детектора переходного излучения (TRD) для эксперимента ALICE в ЦЕРН. Первая установка, включающая сцинтилляционные и черенковские детекторы, применялась при исследованиях элементов TRD на вторичном смешанном электрон-пионном пучке протонного синхротрона PS в ЦЕРН. Вторая установка, состоящая из двух больших сцинтилляционных плоскостей и оригинальной электронной системы, используется в настоящее время для выработки сигнала запуска (триггера) 7-метровых супермодулей TRD в их заключительных стендовых испытаниях с космическими частицами.

Рассматриваются конструкция и характеристики обеих установок.

PACS: 07.77.Ka; 29.40.-n

INTRODUCTION

A transition radiation detector (TRD) is one of the major parts of the ALICE equipment at the Large Hadron Collider (LHC) of CERN [1]. The TRD improves a tracking performance of the ALICE and provides separation of a few GeV/c electrons from a large background of charged particles, mainly pions. The TRD is designed as a huge barrel detector subdivided into 18 units of the 7-m long supermodules containing 6 layers of large-scale drift chambers in a total number of 540. Each chamber includes a radiator, a Xe–CO₂ gas volume, and an anode pad plane with state-of-the-art processing nodes attached as front-end electronics.

An identification of ultrarelativistic electrons stands upon the attendant X-ray photons, produced in the radiator. These photons are absorbed by xenon with an emission of the keV electrons, those provoke an additional local ionization around the absorption point of the gas volume, as well as a relatively significant electric charge to be read out from the pad.

An experimental TRD study with a mixed electron–pion (e/π) beam was an important stage of the TRD group activity, aimed at the following objectives: (1) a better and deeper knowledge of the detector operation; (2) a measurement of the detector characteristics; (3) a development of the ALICE event reconstruction algorithms. Thus, a proper system of scintillation and Cherenkov detectors has been successfully designed and used for a series of experiments with the secondary e/π beam of the CERN proton synchrotron PS in 2002, 2004, and 2007.

Another test facility is a stand-alone cosmic-ray detector complex for the TRD supermodules on closing trial prior to installation in the ALICE set-up frame at CERN.

The supermodule assembling and testing procedures are actually accomplished in Muenster University, Germany.

All systems of the experimental facilities have been designed and produced at JINR, Dubna.

1. FACILITY FOR IN-BEAM TESTS

The GeV electron identification is based on analysis of a time-amplitude information coming from six layers of the chambers. The data outcome depends on the radiator material, the gas mixture, the chamber design, and the TRD operational characteristics. The experiments with the e/π beam have unveiled new information on emission and absorption of the transition radiation photons. These results were used for a final choice of the TRD design in order to get a maximum efficiency of the electrons identification.

The beam detector system is a key element of the experimental test facility at the CERN PS beam line T10. The TRD prototypes and modules were studied with the e/π beam in a momentum range from 1 up to 7 GeV/ c . The system consists of forward and backward detectors, placed in front of and behind the TRD samples along the beam line (Fig. 1).

The forward detectors are characterized by a low background induced by the beam interaction with the detector matter. This part combines two beam counters S1/S2 and the Cherenkov gas detectors ChD. The S1/S2 are gathered up with the $60 \times 60 \times 1$ mm plastic scintillators, while the ChD is equipped with the 2-m long air radiator at normal conditions.

A fast S1 and S2 signal coincidence acts as a trigger to start the data readout on incident beam particles. Each counter's scintillation light, reflected by a thin Al-mylar cone, comes up

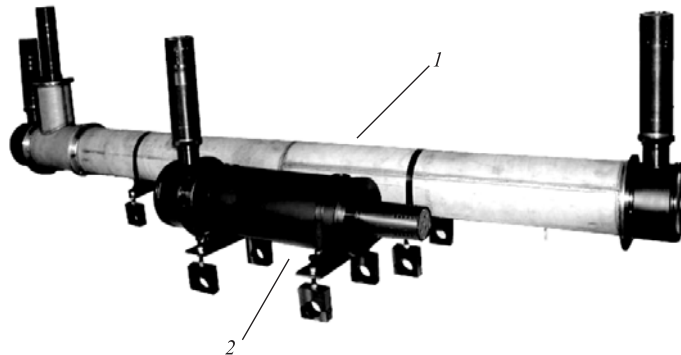

Fig. 1. The forward (1) and backward (2) detectors for the TRD study with the e/π beam

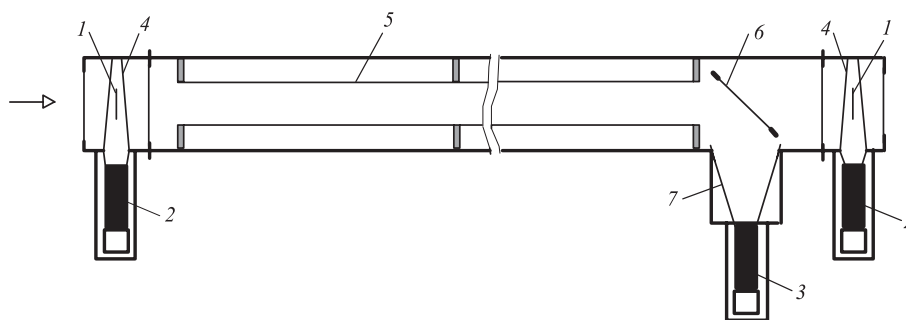

Fig. 2. A structural scheme of the forward detectors: 1 — the plastic scintillator; 2 — the XP2020 PMT; 3 — the PMT XP2020Q; 4 — the Al-mylar light guide; 5 — the Al-kapton light guide (tube); 6 — the Al-mylar mirror; 7 — the Al-mylar light guide (cone)

to a photocathode of the XP2020 photomultiplier (PMT). The ChD, adjusted to a radiation threshold of 4.5 GeV/c for pions, contains a 12- μ m Al-mylar mirror for the Cherenkov light reflection. The light is detected with the XP2020Q PMT. The forward system has been implemented as a single mechanical module (Fig. 2), giving a good detector alignment along the beam axis.

The backward detectors incorporate a scintillation counter S3 and a Cherenkov electromagnetic calorimeter EMC. The S3 and the EMC are also arranged as a single mechanical frame. The EMC is composed by a block of 100 \times 100 \times 350-mm lead glass coupled with the FEU49B PMT. The EMC measures a total energy of the electrons behind the TRD tested. The S3 counter, made of the 60 \times 60 \times 1-mm plastic scintillator, is placed in front of the lead glass block of the calorimeter.

An electron event identification is provided by the two-dimensional analysis of the ChD and EMC responses. For both of these detectors, electrons produce much higher signal amplitudes in comparison to pions of the same momentum. The measurements indicate a high-quality selection of the electron events even if electrons form a small fraction of the beam particles mixture. It is a crucial point because the electron fraction decreases dramatically with a momentum rise.

The first testing run was carried out over a small TRD prototype at CERN in September 2002. Figure 3 presents three plots of the ChD–EMC pulse height correlation for different momentum magnitudes of 2, 4, and 6 GeV/c. The EMC signal is proportional to the electron

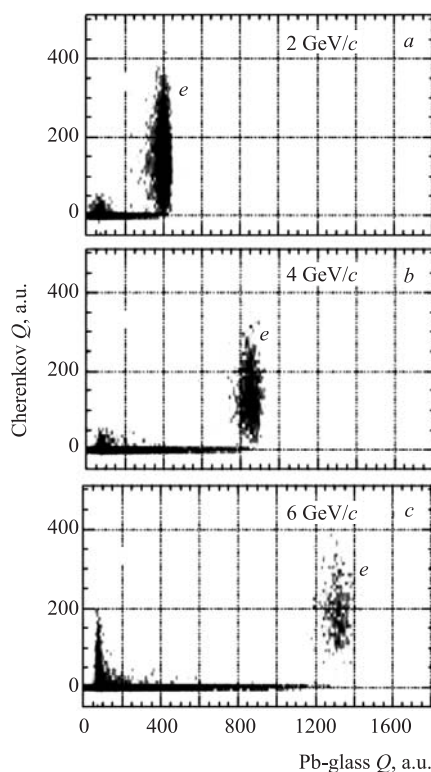

Fig. 3. The electron events (*e*), selected with the two-dimensional analysis, the ChD versus EMC pulse heights (in ADC channels), for three different momentum magnitudes

momentum, while pions give just a small amplitude contribution in the momentum interval under investigation. At the 6-GeV/ c momentum, pions overlap an electron area of the ChD response. However, the ChD–EMC two-dimensional analysis results in a very good selection of pure electron events labeled graphically with « e ».

The next two testing runs were accomplished with a real 6-chamber section and the first TRD supermodule, respectively, in 2004 and 2007.

In these experiments, it has been proven that the beam detector system was a good instrument for a reliable separation of electrons from pions in the momentum range of 1–7 GeV/ c . The measurements have allowed one to study the TRD characteristics, the background effects, and the transition radiation photon spectrum as well. The stable several-week system operation was an important factor for the successful experimental program with the e/π beam.

The most significant results have been published in [2–6].

2. COSMIC-RAY TEST FACILITY

Cosmic rays stand out against accelerator beams as a unique natural source of high-energy single-charged particles, mainly muons, giving an experimenter a very suitable opportunity for investigation of large-scale detectors. An average cosmic flux is $\sim 150 \text{ m}^{-2} \cdot \text{s}^{-1}$ or $\sim 540000 \text{ m}^{-2}$ per hour at sea level.

Generally, a cosmic-ray test facility contains two or more scintillation planes to produce a trigger signal. The plane geometry specifies an acceptance and selection of cosmic particle trajectories, defining the limits of counting rates and event statistics.

This section presents the TRD/ALICE stand-alone cosmic-ray test facility with two large scintillation planes positioned above and under of the 7-m long TRD supermodule on trial. A general layout of the facility is shown in Fig. 4.

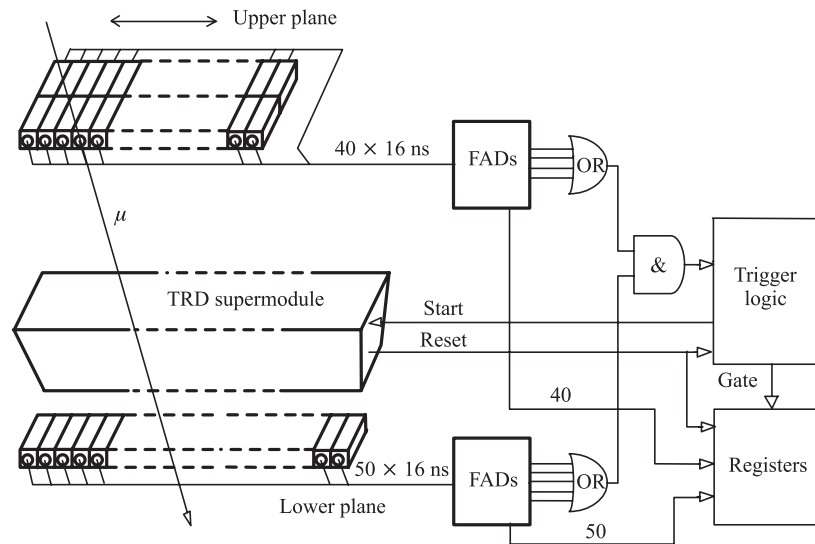

Fig. 4. A general layout of the facility for the TRD supermodule tests with cosmic particles. FADs — the fast adders-amplifiers-discriminators

The upper scintillation plane contains 20 units of 86-cm long scintillation strips each of 2-cm thickness. This plane occupies an active area of 20×2 strips with the total dimension of 173×230 cm. The plane has a special mechanical support that can be moved by rollers along the TRD supermodule placed on a special table below. This makes it feasible to scan the supermodule sector by sector depending on the upper plane position. So, a single supermodule measurement cycle requires five different positions of the upper plane, and about one-week time period is needed to get a good statistics of events induced by cosmic muons.

The lower scintillation plane is fixed down by the floor under the supermodule. It includes 50 shorter scintillation strips, covering an active area of 65.5×575 cm.

All strips have been fashioned from the plastic bars extruded in Kharkov, Ukraine.

Figures 5 and 6 show outward appearance of both planes assembled and put into operation in Muenster University, Germany.

The FEU183-1 PMTs have been chosen for detection of light photons produced by cosmic particles in the scintillation strips. The PMT photocathodes are tightly attached to the strip edges with an intermediate optical grease improving the counter responses. All PMTs, tied together with the high-resistance high-voltage dividers, are encapsulated into the soft iron housings.

A low counting rate, estimated for the cosmic particles, permits decreasing the PMT divider's current down to $\sim 50 \mu\text{A}$. It allows one to reduce a number of channels in the high-voltage (HV) power system which can be realized with a more simple and inexpensive technical solution. Only one channel was used to supply a group of 10 PMTs via a passive HV fan-out box. These boxes are also visible in Figs. 5 and 6.

To implement a fast trigger for measurements with the cosmic particles, some special multichannel electronics was necessary to meet the following requirements:

- A low scintillation counter pulse height with the mean value of about 10 mV applied to the 50 Ohm load;
- A minimum electronics share in the total 100 ns trigger budget, filled out with delays from scintillators, PMTs, trigger logic, and cables;
- A high density of inexpensive electronic channels interconnected in the frame of the standard modular system.

Thus, a unified modular system of the fast, stackable, adders-amplifiers-discriminators (FADs) has been designed, constructed and applied [7]. Each system channel includes a

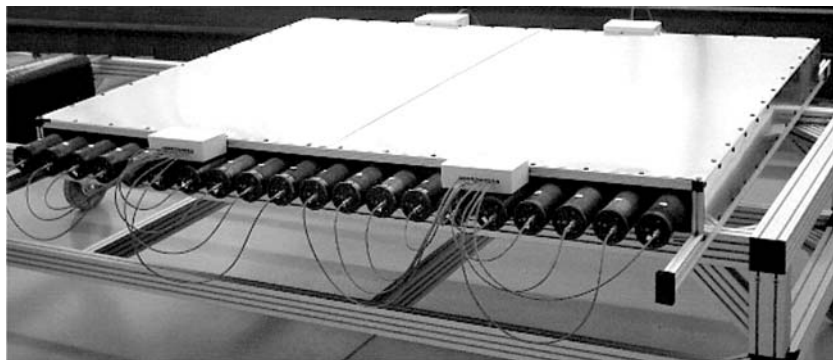

Fig. 5. The upper scintillation plane

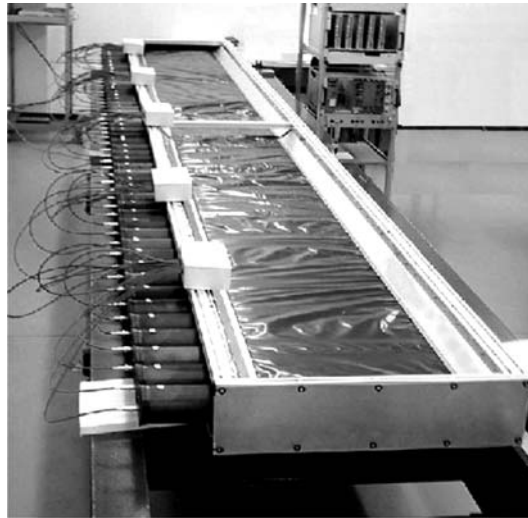

Fig. 6. The lower scintillation plane

linear adder of two PMT signals, a fast amplifier of the sum pulse, a high-speed leading edge discriminator of the amplified sum, and a fast ECL shaper as well.

The main FAD parameters are a gain factor of 20 or 26 dB, the 130-MHz signal bandwidth, the 20-ns internal delay, and a signal charge sensitivity of 28 fC with the 4-mV minimum limit of a regulated discrimination threshold for amplified signals.

Figure 7 images the 4-input autonomous FAD basic cell, sized with the 120×30 mm dimension, and a fragment of the FAD-based system combining 16-input standard NIM modules.

For the first stage of the cosmic test facility adjustment, an amplitude distribution of every scintillation counter was measured at the same HV value. Then, in order to reduce a dispersion of results towards getting the similar distributions, all 90 counters have been

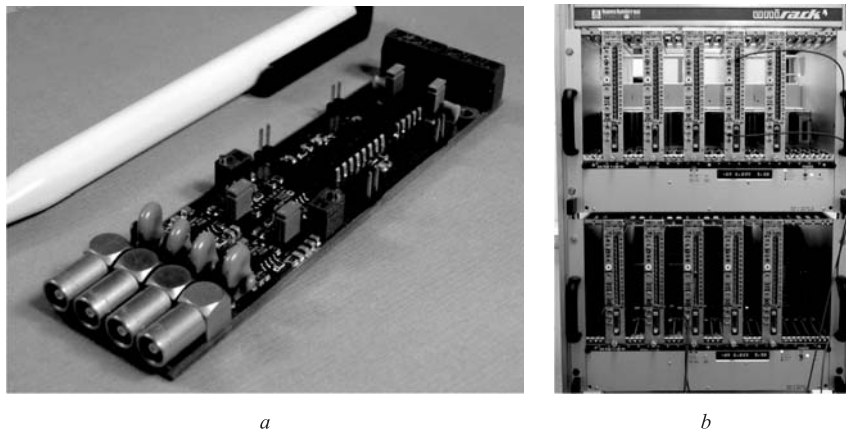

Fig. 7. The FAD basic cell (*a*) and a fragment of the FAD-based modular system (*b*)

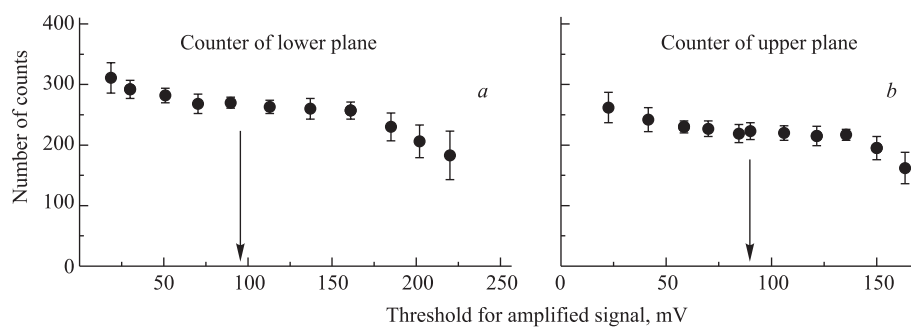

Fig. 8. Counting cosmic rate versus discrimination thresholds of the amplified signals (Gain = 10) for two counters of the scintillation planes

divided into 9 groups with an optimum HV magnitude fixed to each group individually. At last, the measurements of a cosmic counting rate versus a discrimination threshold were performed for all groups. Every of these 9 measuring cycles has been conducted with one accessory triggering counter and one scintillation counter sampled from a group. Figure 8 presents two plots as the graphic patterns obtained for selected counters of the lower and one upper planes. Each of the plots indicates a long and flat plateau. The operational thresholds, selected in the middle parts of plateau, are shown by arrows. In both cases the gain factor was fixed at 20 dB (10). Under this amplification, for the lower plane counter this operational threshold was set at 96 mV to discriminate the output PMT signals of the 20 mV mean amplitude, while for the upper plane counter these parameters were valued as 93 and 17 mV, respectively.

A final goal of adjustment is operation of the cosmic-ray test facility in an optimum regime corresponding to an effective selection of events induced by cosmic particles. The low-noise PMTs and the fast-processing FADs provide a negligible background contribution to the trigger signal rate. The test measurements showed that the total counting rate was about 1500 Hz for the cosmic particle events and noise together. As soon as the facility's trigger is formed by a 100-ns coincidence of signals from both planes, it was expected that a real cosmic trigger could be considered as a dominating factor under negligible contribution of background signals. The facility's trigger counting rate was evaluated as ~ 30 Hz.

Acknowledgements. The authors would like to thank Prof. J. Stachel from Heidelberg University, Prof. J. Wessels and B. Bathen from Muenster University, A. Adronic from GSI, Darmstadt, and Prof. Yu. V. Zanevski from JINR, Dubna, for cooperation, support and stimulating discussions.

We are also very grateful to D. Kostilev, V. Pavlyukevich and P. Sazhin from JINR, Dubna, for participation in the detector production and test measurements.

REFERENCES

1. Transition Radiation Detector. ALICE Technical Design Report. CERN/LHCC 2001-021. 2001.
2. Adronic A. *et al.* // Nucl. Instr. Meth. A. 2004. V. 519. P. 508–517.
3. Adronic A. *et al.* // Ibid. V. 525. P. 447–457.

4. *Adler C. et al.* // Nucl. Instr. Meth. A. 2005. V. 540. P. 140–157.
5. *Adler C. et al.* // Ibid. V. 552. P. 364–371.
6. *Adronic A. et al.* // Nucl. Instr. Meth. A. 2006. V. 558. P. 516–525.
7. *Efimov L.* A Modular System of the Fast, Stackable, Adders-Amplifiers-Discriminators at Large Scintillator Counters for Triggering the TRD/ALICE Cosmic Test Facility // Proc. of the XXI Intern. Symp. on Nucl. Electronics «NEC'2007» (Varna, 2007); JINR, E10/11-2008-37. Dubna, 2008. P. 187–197.

Received on June 9, 2008.